



PLANNING- AND INSTALLATION MANUAL

Steam humidifier
Condair RS

Thank you for choosing Condair

Installation date (MM/DD/YYYY):

Commissioning date (MM/DD/YYYY):

Site:

Model:

Serial number:

Proprietary Notice

This document and the information disclosed herein are proprietary data of Condair Group AG. Neither this document, nor the information contained herein shall be reproduced, used, or disclosed to others without the written authorisation of Condair Group AG, except to the extent required for installation or maintenance of recipient's equipment.

Liability Notice

Condair Group AG does not accept any liability due to incorrect installation or operation of the equipment or due to the use of parts/components/equipment that are not authorised by Condair Group AG.

Copyright Notice

© Condair Group AG, All rights reserved.

Misapprehension and Technical modifications reserved

Contents

1	Introduction	5
1.1	To the very beginning	5
1.2	Notes on the installation manual	5
2	For your safety	7
3	Product Overview	9
3.1	Calculating the maximum required steam capacity	9
3.2	Models overview	10
3.2.1	Single units Small ("S"), RS 5 - 10 and Medium ("M"), RS 16 - 40	10
3.2.2	Single units Large (Double housing "L"), RS 50 - 80	11
3.2.3	Double units (2 x single housings "M"), RS 40 - 80	12
3.2.4	Linkup systems (3 x single housings "M"), RS 100 - 120	13
3.2.5	Linkup systems (4 x single housings "M"), RS 140 - 160	14
3.3	Product designation	15
3.4	Options	17
3.5	Accessories	19
3.5.1	Accessories overview	19
3.5.2	Accessory details	20
3.5.2.1	DV81-... steam distribution pipe	20
3.5.2.2	OptiSorp steam distribution system	21
3.5.2.3	Blower pack	22
4	Receiving and storage	23
4.1	Inspection	23
4.2	Storage and Transportation	24
5	Mounting and installation work	25
5.1	Safety notes on mounting and installation work	25
5.2	Installation overviews	26
5.3	Mounting the unit	28
5.3.1	Notes on locating the unit	28
5.3.2	Mounting the humidifier	30
5.3.3	Inspecting the installed unit	32
5.4	Steam installation	33
5.4.1	Overview steam installation for duct humidification	33
5.4.2	Positioning of the steam distributor	35
5.4.3	Installing the steam distributors	40
5.4.4	Positioning and mounting of the blower packs (accessory BP)	41
5.4.5	Installing the steam and condensate lines	42
5.4.6	Common steam and condensate line errors	46
5.4.7	Inspecting the steam installation	47

5.5	Water installation	48
5.5.1	Overview water installation	48
5.5.2	Notes on water installation	49
5.5.3	Inspecting the water installation	51
5.6	Notes on humidity control systems/humidity control	52
5.6.1	System 1 – Room humidity control	52
5.6.2	System 2 – Room humidity control with continuous limitation of the supply air humidity	52
5.6.3	System 3 – Supply air humidity control with continuous output limitation	53
5.6.4	Which humidity control system for which application	53
5.6.5	Admissible control signals	54
5.7	Electrical installation	55
5.7.1	Notes on electrical installation	55
5.7.2	Wiring diagram Condair RS - Single units "S" and "M" (5...40 kg/h)	56
5.7.3	Wiring diagram Condair RS - Single units "L" 50...80 kg/h (double housing)	57
5.7.4	Wiring diagram Condair RS - Double units (2 x single housings "M") 40...80 kg/h	58
5.7.5	Wiring diagram RS - Linkup systems 100...160 kg/h	59
5.7.6	Installation work external connections	61
5.7.7	Inspecting the electrical installation	70
6	Product specifications	71
6.1	Performance data / Fuses "F3" Heating voltage supply	71
6.2	Operating data	72
6.3	Connections/Dimensions/Weights	72
6.4	Certificates	73
6.5	Standard settings for water reduction time and maintenance interval time dependent on the water quality	73
7	Appendix	74
7.1	Dimensional drawings	74
7.1.1	Dimensional drawing RS 5 - 10, size "S"	74
7.1.2	Unit dimensions RS 16 - 40 and RS 40 - 80 (single housing), size "M"	75
7.1.3	Unit dimensions RS 50 - 80 (double housing), size "L"	76
7.2	EC Declaration of conformity	77
7.3	h,x diagram	78

1 Introduction

1.1 To the very beginning

We thank you for having purchased the **Condair RS steam humidifier**.

The Condair RS steam humidifier incorporates the latest technical advances and meets all recognized safety standards. Nevertheless, improper use of the Condair RS steam humidifier may result in danger to the user or third parties and/or damage to property.

To ensure a safe, proper, and economical operation of the Condair RS steam humidifier, please observe and comply with all information and safety instructions contained in the present documentation as well as in the separate documentations of the components installed in the humidification system.

If you have questions after reading this documentation, please contact your Condair partner. They will be glad to assist you.

1.2 Notes on the installation manual

Limitation

The subject of this installation manual is the Condair RS steam humidifier in its different versions. The various options and accessories are only described insofar as is necessary for proper operation of the equipment. Further information on options and accessories can be obtained in their respective instructions.

This installation manual is restricted to the **installation** of the Condair RS steam humidifier and is meant for **well trained personnel being sufficiently qualified for their respective work**.

This installation manual is supplemented by various separate items of documentation (operation manual, spare parts list, etc.), which are included in the delivery as well. Where necessary, appropriate cross-references are made to these publications in the installation manual.

Symbols used in this manual



CAUTION!

The catchword "CAUTION" used in conjunction with the caution symbol in the circle designates notes in this installation manual that, if neglected, may cause **damage and/or malfunction of the unit or damage to property**.



WARNING!

The catchword "WARNING" used in conjunction with the general caution symbol designates safety and danger notes in this installation manual that, if neglected, may cause **injury to persons**.



DANGER!

The catchword "DANGER" used in conjunction with the general caution symbol designates safety and danger notes in this installation manual that, if neglected, may lead to **severe injury or even death of persons**.

Safekeeping

Please safeguard this installation manual in a safe place, where it can be immediately accessed. If the equipment changes hands, the documentation must be passed on to the new operator.

If the documentation gets misplaced, please contact your Condair partner.

Language versions

This installation manual is available in other languages. Please contact your Condair partner for information.

2 For your safety

General

Every person, who is in charge of the installation work on the Condair RS must have read and understood this installation manual and the Condair RS operation manual before carrying out any work.

Knowing and understanding the contents of the installation manual and the operation manual is a basic requirement for protecting personnel against any kind of danger, to prevent faulty operation, and to operate the unit safely and correctly.

All icons, signs and markings applied to the Condair RS must be observed and kept in readable state.

Qualification of personnel

All installation work described in this installation manual **may only be carried out by specialists who are well trained and adequately qualified and are authorised by the customer.**

For safety and warranty reasons any action beyond the scope of this manual must be carried out only by qualified personnel authorised by Condair.

It is assumed that all persons working with the Condair RS are familiar and comply with the appropriate regulations on work safety and the prevention of accidents.

Intended use

The Condair RS steam humidifier is intended exclusively for air humidification via a steam distributor or blower pack approved by Condair within specified operating conditions (see Condair RS operation manual). Any other type of application, without the written consent of Condair, is considered as not conforming with the intended purpose and may lead to the Condair RS becoming dangerous and will void any warranty.

Operation of the equipment in the intended manner requires **that all the information contained in this installation manual are observed (in particular the safety instructions).**

Danger that may arise from the Condair RS



DANGER!
Danger of electric shock!

The Condair RS is mains powered. Live parts may be exposed when the unit is open. Touching live parts may cause severe injury or danger to life.

Prevention: The Condair RS must be connected to the mains only after all mounting and installation work has been completed, all installations have been checked for correct workmanship and the unit is closed and properly locked.

Preventing unsafe operation

All persons working with the Condair RS are obliged to report any alterations to the unit that may affect safety to the owner without delay and to **secure the Condair RS against accidental power-up**.

Prohibited modifications to the unit

No modifications must be undertaken on the Condair RS without the express written consent of Condair.

For the replacement of defective components use exclusively **original accessories and spare parts** available from your Condair partner.

3 Product Overview

3.1 Calculating the maximum required steam capacity

The maximum required steam capacity must be calculated based on one of the following formulas:

$$m_D = \frac{V \cdot \rho}{1000} \cdot (x_2 - x_1) \quad \text{oder} \quad m_D = \frac{V}{1000 \cdot \varepsilon} \cdot (x_2 - x_1)$$

m_D : maximum steam demand in **kg/h**

V : volume of supply air portion per hour in **m³/h** (for indirect room humidification) or room volume to be humidified per hour in **m³/h** (for direct room humidification)

ρ : specific gravity of air in **kg/m³**

ε : specific volume of air in **m³/kg**

x_2 : desired absolute room air humidity in **g/kg**

x_1 : minimum absolute supply air humidity in **g/kg**

The values for ρ , ε , x_2 and x_1 can be gathered from the **h,x-diagram** or the **Carrier-Diagram** for moist air respectively.

3.2 Models overview

Condair RS steam humidifiers are available as **single units with different housing sizes (S, M and L)**, as **double units (2 x "M")** and as **Linkup systems (3 x "M" or 4 x "M")** with **different heating voltages and steam capacities ranging from 5 kg/h up to a maximum of 160 kg/h.**

3.2.1 Single units Small ("S"), RS 5 - 10 and Medium ("M"), RS 16 - 40

Housing size	Condair	230 V/1~	200V/3~	230V/3~	380V/3~	400V/3~	415V/3~	440V/3~	460V/3~	480V/3~	500V/3~	600V/3~
		kg/h	kg/h	kg/h	kg/h	kg/h	kg/h	kg/h	kg/h	kg/h	kg/h	kg/h
S	RS 5	5.0	—	5.0	4.6	5.0	5.4	—	—	—	—	—
	RS 8	8.0	—	8.0	7.3	8.0	8.7	—	—	—	—	—
	RS 10	9.8	—	9.8	9.0	10.0	10.7	10.8	11.8	12.8	13.9	10.3
M	RS 16	—	14.9	16.0	14.5	16.0	17.3	15.3	16.7	18.2	19.8	14.2
	RS 20	—	18.1	19.7	17.9	20.0	21.4	17.2	18.8	20.5	22.2	21.3
	RS 24	—	22.3	24.0	21.8	24.0	26.0	—	—	—	—	—
	RS 30	—	30.0	29.5	26.9	30.0	32.0	24.0	26.2	28.6	31.0	32.0
	RS 40	—	—	—	36.1	40.0	43.1	36.0	39.4	42.9	46.5	42.7



Abb. 1: Overview single units Small ("S") and Medium ("M")

3.2.2 Single units Large (Double housing "L"), RS 50 - 80

Housing size	Condair	230 V/1~	200V/3~	230V/3~	380V/3~	400V/3~	415V/3~	440V/3~	460V/3~	480V/3~	500V/3~	600V/3~
		kg/h	kg/h	kg/h	kg/h	kg/h	kg/h	kg/h	kg/h	kg/h	kg/h	kg/h
L	RS 50	—	—	—	—	50.0	53.4	—	—	—	—	—
L	RS 60	—	—	—	—	60.0	64.0	—	—	—	—	—
L	RS 80	—	—	—	—	80.0	86.2	—	—	—	—	—

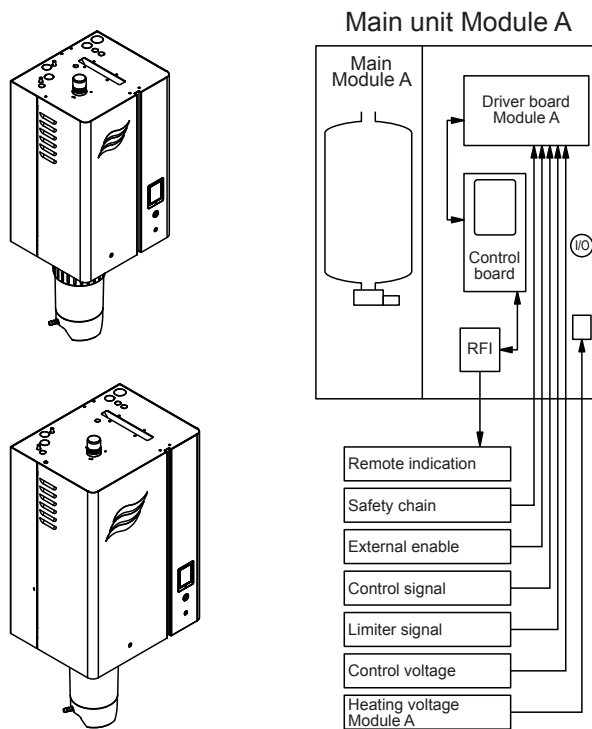

Abb. 2: Overview single units Large ("L")

3.2.3 Double units (2 x single housings "M"), RS 40 - 80

Housing size	Condaair	230 V/1~	200V/3~	230V/3~	380V/3~	400V/3~	415V/3~	440V/3~	460V/3~	480V/3~	500V/3~	600V/3~
		kg/h	kg/h	kg/h	kg/h	kg/h	kg/h	kg/h	kg/h	kg/h	kg/h	kg/h
2*M	RS 40	—	2*18.1	2*19.7	—	—	—	—	—	—	—	—
	RS 50 A + B	—	18.1 + 30.0	19.7 + 29.5	17.9 + 26.9	20.0 + 30.0	21.4 + 32.0	17.2 + 24.0	18.8 + 26.2	20.5 + 28.6	22.2 + 31.0	21.3 + 32.0
2*M	RS 60	—	2*30.0	2*29.5	2*26.9	2*30.0	2*32.0	2*24.0	2*26.2	2*28.6	2*31.0	2*32.0
2*M	RS 80	—	—	—	2* 36.1	2*40.0	2*43.1	2*36.0	2*39.4	2*42.9	2*46.5	2*42.7

A= Module A, B= Module B

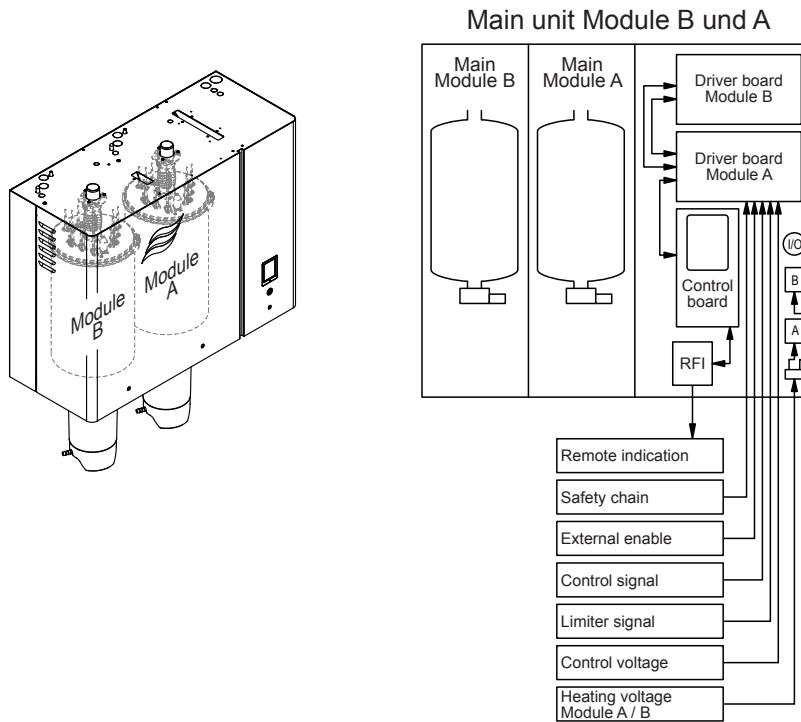

Abb. 3: Overview Double units (2 x "M")

3.2.4 Linkup systems (3 x single housings "M"), RS 100 - 120

Housing size	Condair	230 V/1~	200 V/3~	230 V/3~	380 V/3~	400 V/3~	415 V/3~	440 V/3~	460 V/3~	480 V/3~	500 V/3~	600 V/3~
		kg/h	kg/h	kg/h	kg/h	kg/h	kg/h	kg/h	kg/h	kg/h	kg/h	kg/h
3*M	RS 100	—	—	—	—	2*30.0 + 40.0	2*32.0 + 43.1	—	—	—	—	—
	RS 120	—	—	—	—	3*40.0	3*43.1	—	—	—	—	—

M= Main unit, E= Extension unit

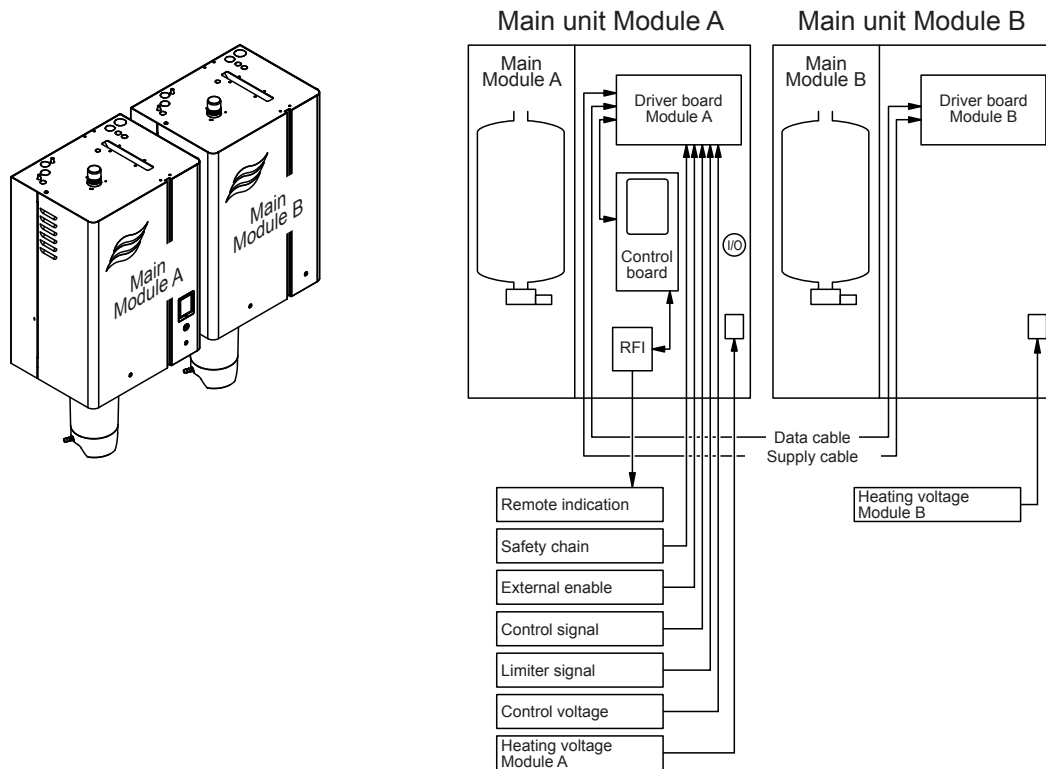

Abb. 4: Overview Linkup systems (3 x "M")

3.2.5 Linkup systems (4 x single housings "M"), RS 140 - 160

Housing size	Condair	230 V/1~	200 V/3~	230 V/3~	380 V/3~	400 V/3~	415 V/3~	440 V/3~	460 V/3~	480 V/3~	500 V/3~	600 V/3~
		kg/h	kg/h	kg/h	kg/h	kg/h	kg/h	kg/h	kg/h	kg/h	kg/h	kg/h
4*M	RS 140	—	—	—	—	2*30.0 + 2*40.0	2*32.0 + 2*43.1	—	—	—	—	—
	RS 160	—	—	—	—	4*40.0	4*43.1	—	—	—	—	—

M= Main unit, E= Extension unit

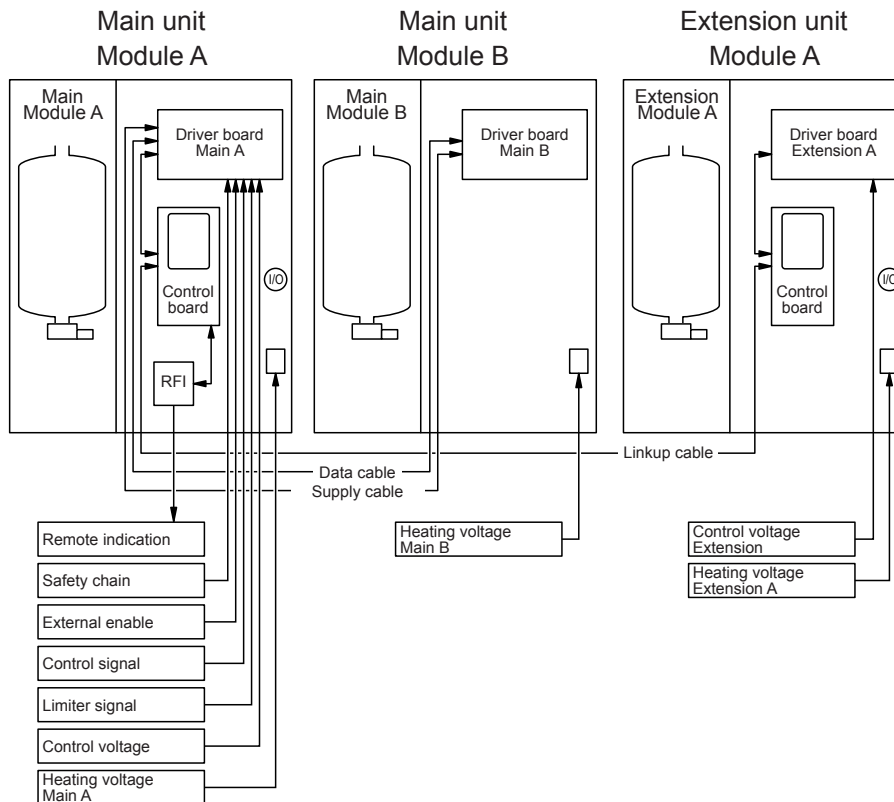
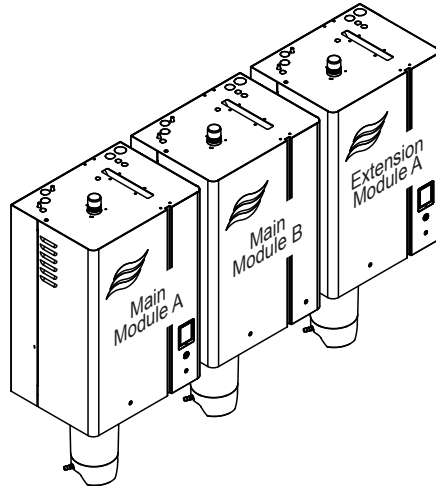

Abb. 5: Overview Linkup systems (4 x "M")

3.3 Product designation

The identification of the unit is found on the specification label.

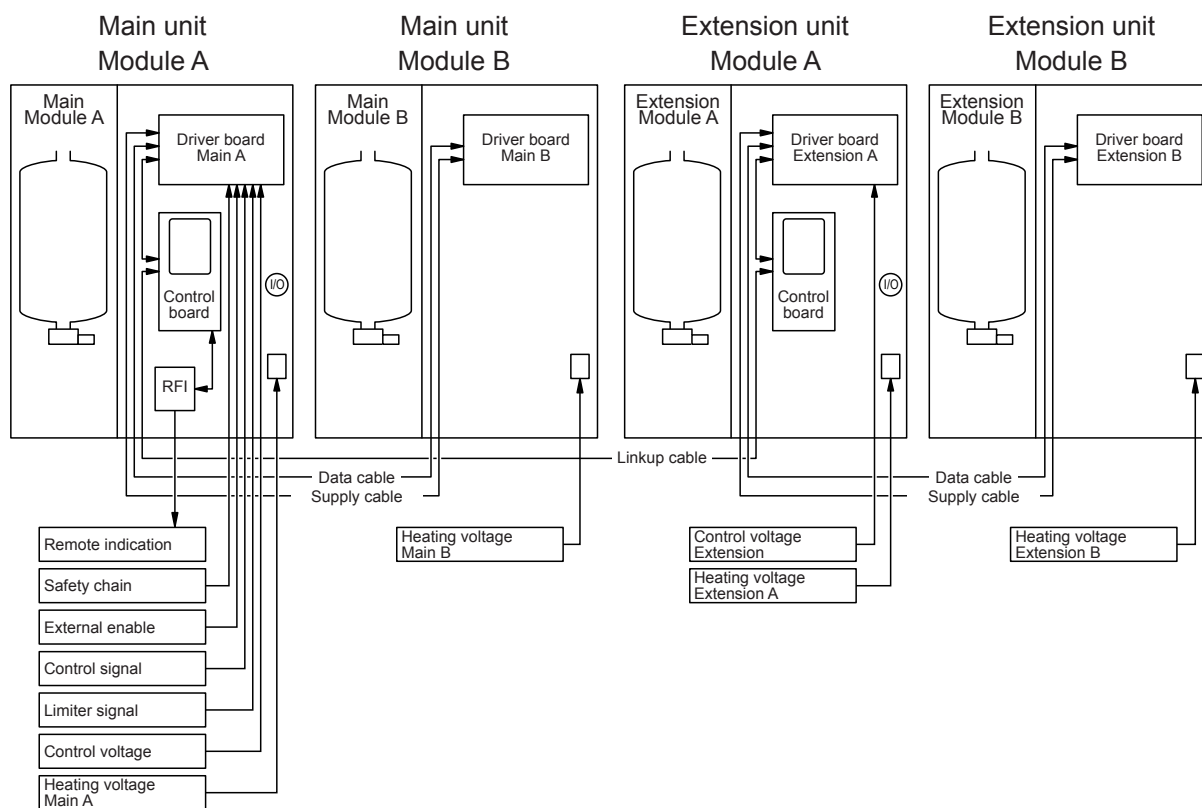
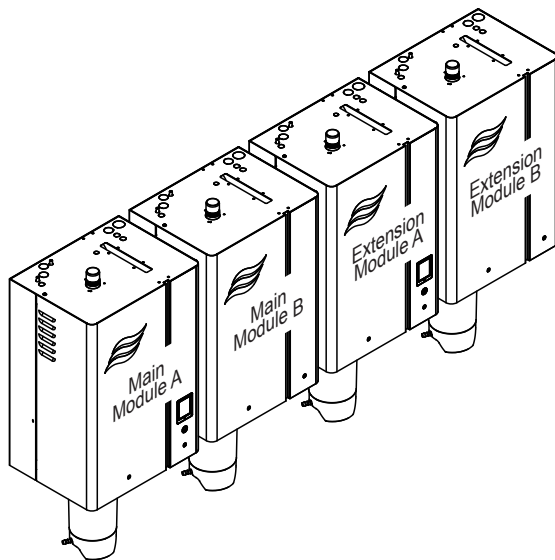

Abb. 6: Location of the specification label

Key model designation

Example:

Condair RS 50 L 400V/3~ P VE

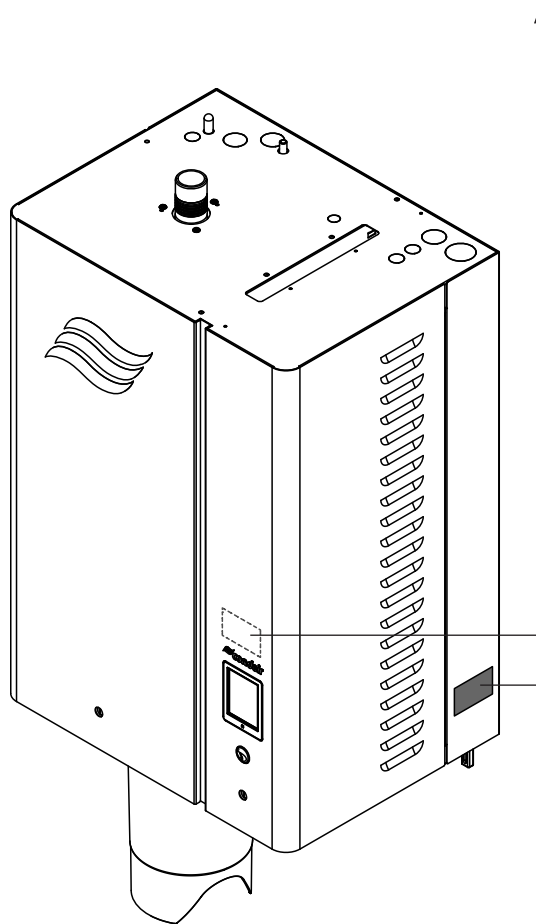
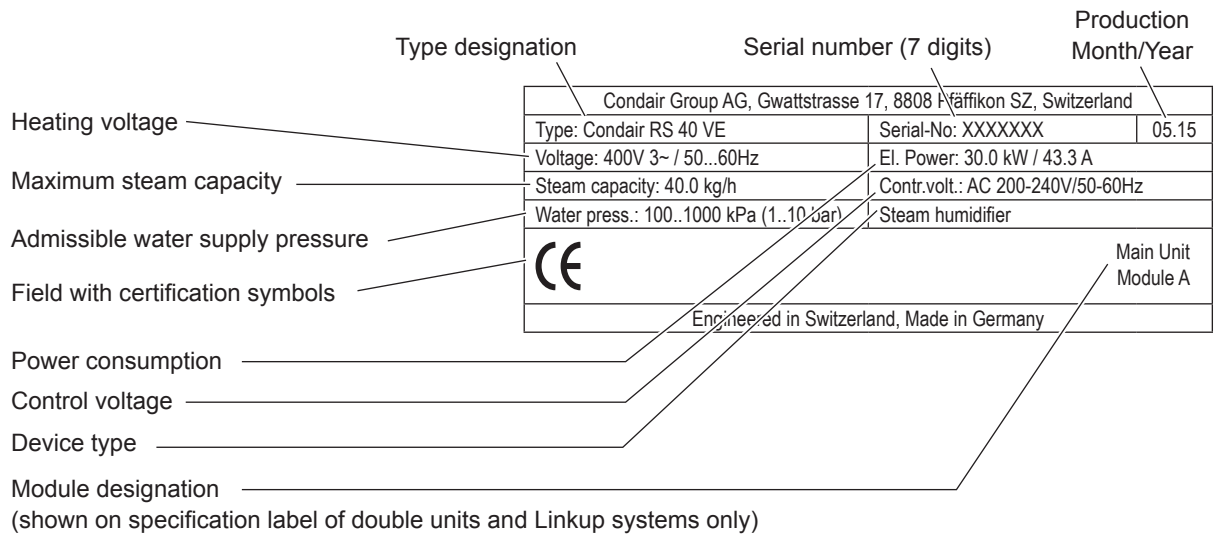
Product designation _____

Unit model: _____

Housing size: _____

L: large housing

Heating voltage: _____

230V/1~/50...60Hz: **230V/1~**

200V/3~/50...60Hz: **200V/3~**

230V/3~/50...60Hz: **230V/3~**

380V/3~/50...60Hz: **380V/3~**

400V/3~/50...60Hz: **400V/3~**

415V/3~/50...60Hz: **415V/3~**

440V/3~/50...60Hz: **440V/3~**

460V/3~/50...60Hz: **460V/3~**

480V/3~/50...60Hz: **480V/3~**

500V/3~/50...60Hz: **500V/3~**

600V/3~/50...60Hz: **600V/3~**

Control accuracy: _____

P: high control accuracy

Water management: _____

VE: without lime collector tank for de-ionized water

3.4 Options

		Condair RS				
		Housing size				
Voltage	Small (S)	Medium (M)	Double (2xM)	Large (L)	Linkup (3xM)	Linkup (4xM)
230V/1~	5...10	—	—	—	—	—
200V/3~	—	16...30	40...60	—	—	—
230V/3~	5...10	16...30	40...60	—	—	—
380V/3~	5...10	16...40	50...80	—	—	—
400...415V/3~	5...10	16...40	50...80	50...80	100...120	140...160
440...600V/3~	10	16/20/30/40	50...80	—	—	—
Accessory board PCB with relay contacts for the connection of remote fan enable (cylinder A/B) as well as remote enable of an external hygiene flush valve in the water supply line (cylinder A/B).	1xACC			2xACC		
Pressure compensation kit Assembly kit for the installation of the filling cup on the equipment cover, for the operation of the steam humidifier in installations with duct air pressures up to 10'000 Pa.	1xOVP		2xOVP		3xOVP	4xOVP
Transformer for internal control voltage supply (for 400...500 V mains supplies without neutral conductor) Kit including terminal strip and transformer to provide control voltage supply for sites with 3 phase single voltage supply without neutral conductor. Only available for supply voltages 400...500 V/3~/50...60 Hz.	1xTR-S (RS 5 ... RS 20) 1xTR-M (RS 24 ... RS 40)		1xTR-S (RS 50) or 1xTR-M (RS 60/RS80)	1xTR-L ¹⁾		2xTR-M
CVI for internal control voltage supply (for 400...415 V mains supplies with neutral conductor) Terminal strip kit to provide control voltage supply for sites with 3 phase single voltage supply with neutral conductor. Only available for supply voltages 400...415 V/3~N/50...60 Hz.	1xCVI-S	1xCVI-M		1xCVI-L ¹⁾		2xCVI-M
Terminal block heating voltage Terminal block for "L" units for the connection of two separate heating voltage supply lines. Note: As standard "L" units are equipped with a TC terminal block for a single heating voltage supply line.	—			1xTHV-L		—
LonWorks board Supplementary board to connect the Condair RS to a building management system via LonWorks.	1xLW					

Condair RS						
Housing size						
Voltage	Small (S)	Medium (M)	Double (2xM)	Large (L)	Linkup (3xM)	Linkup (4xM)
230V/1~	5...10	—	—	—	—	—
200V/3~	—	16...30	40...60	—	—	—
230V/3~	5...10	16...30	40...60	—	—	—
380V/3~	5...10	16...40	50...80	—	—	—
400...415V/3~	5...10	16...40	50...80	50...80	100...120	140...160
440...600V/3~	10	16/20/30/40	50...80	—	—	—
Total drain valve Set including solenoid drain valve and hose for automatic draining of the lime collector tank.	1xSV		2xSV		3xSV	4xSV
Insulation jacket for steam cylinder	1xIC-S	1xIC-M	2xIC-M		3xIC-M	4xIC-M
Special steam cylinder Special steam cylinder with nickel-plated heating elements for highly corrosive water (conductivity <1 µS/cm, chloride content >30 mg/l).	1xUPW-S	1xUPW-M	2xUPW-M		3xUPW-M	4xUPW-M
Drain water cooling set Set including special inlet valve, hose and support for drain water cooling.	1xDWC-S	1xDWC-M	2xDWC-M		3xDWC-M	4xDWC-M

¹⁾ For "L" units only possible if they are connected with two separate heating voltage supply lines (via Option THV-L).

3.5 Accessories

3.5.1 Accessories overview

		Condair RS					
		Housing size					
Voltage	Small (S)	Medium (M)	Double (2xM)	Large (L)	Linkup (3xM)	Linkup (4xM)	
230V/1~	5...10	—	—	—	—	—	
200V/3~	—	16...30	40...60	—	—	—	
230V/3~	5...10	16...30	40...60	—	—	—	
380V/3~	5...10	16...40	50...80	—	—	—	
400...415V/3~	5...10	16...40	50...80	50...80	100...120	140...160	
440...600V/3~	10	16/20/30/40	50...80	—	—	—	
Steam distribution pipe Steam distribution pipe for steam distribution inside a air duct (see details in chapter 3.5.2.1).	1xDV81		2xDV81		3xDV81	4xDV81	
Steam distribution system OptiSorp Steam distribution system for steam distribution inside a air duct for reduced absorption distances (see details in chapter 3.5.2.2).	OptiSorp System 1		OptiSorp System 2		OptiSorp System 3	OptiSorp System 4	
Blower pack Blower pack for direct room humidification. The blower pack can be mounted either directly onto the Condair RS or separated from the unit to the wall (see details in chapter 3.5.2.3).	1xBP		2xBP		3xBP	4xBP	
Support steam for distribution pipe Support for vertical mounting of the steam distribution pipe DV81-....	1xVS-DV81		2xVS-DV81		3xVS-DV81	4xVS-DV81	
Steam hose (ø57/45 mm) / meter	1xDS80		2xDS80		3xDS80	4xDS80	
Condensate hose (ø12/8 mm) / meter	1xKS10		2xKS10		3xKS10	4xKS10	
Overpressure safety valve Overpressure safety valve for installation in the steam line directly after the steam outlet of the unit.	1xSTO		2xSTO		3xSTO	4xSTO	
Filter valve Filter valve for the installation in the water supply line.	1xZ261		2xZ261		3xZ261	4xZ261	
Mounting rack basic Mounting rack for Condair RS.	1xMR-B		2xMR-B	1xMR-L ¹⁾	3xMR-B	4xMR-B	
Height extension profiles for mounting rack basic Height extension profiles for mounting rack.	1xMR-E		2xMR-E	—	3xMR-E	4xMR-E	
Screw feet for mounting rack basic Screw feet for levelling the mounting rack.	1xMR-A		2xMR-A	—	3xMR-A	4xMR-A	

¹⁾ Reinforced mounting rack for "L" units including adjustable feet

3.5.2 Accessory details

3.5.2.1 DV81-... steam distribution pipe

The steam distribution pipes are selected on the basis of the **duct width "B"** (for horizontal installation) or the **duct height "H"** (for vertical installation) and the **capacity of the steam humidifier**.

Important! Always select the longest possible steam distribution pipe (optimum humidification distance).

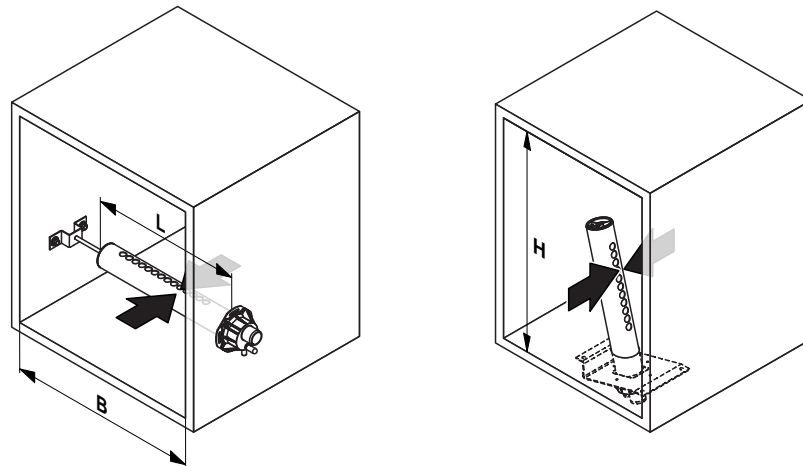

Steam distribution pipe DV81-... made of CrNi steel		Duct width/duct height	Max. Steam capacity
Type	Length in mm (L) ***	in mm	in kg/h
DV81-200 *	200	210...400	10
DV81-350 **	350	400...600	30
DV81-500 **	500	600...750	30
DV81-650	650	750...900	50
DV81-800	800	900...1100	50
DV81-1000	1000	1100...1300	50
DV81-1200	1200	1300...1600	50
DV81-1500	1500	1600...2000	50
DV81-1800	1800	2000...2400	50
DV81-2000	2000	2200...2600	50
DV81-2300	2300	2500...2900	50
DV81-2500	2500	2700...3100	50

* for units with steam capacities up to a maximum of 10 kg/h only

** for units with steam capacities up to a maximum of 30 kg/h only

*** Special length on request

Note: for further information regarding the DV81-... steam distribution pipe please refer to the separate installation and operating instructions of this product.

3.5.2.2 OptiSorp steam distribution system

The **OptiSorp** steam distribution system is used in ventilation ducts with a short humidification distance (for the calculation of the humidification distance refer to [chapter 5.4.2](#)). When ordering an **OptiSorp** system the duct dimension must be specified. Please consult the data in the following table:

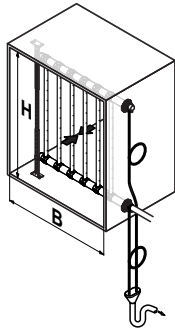
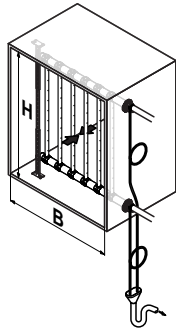
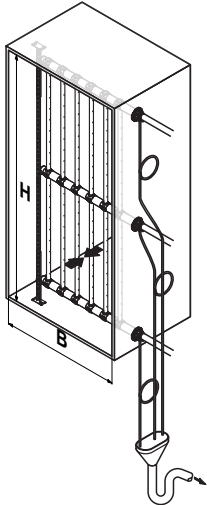
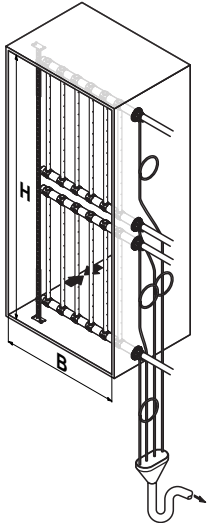
	System 1	System 2	System 3	System 4
				
Number of steam connector	1	2	3	4
Max. steam capacity	45 (30) kg/h	90 (60) kg/h	135 (90) kg/h	180 (120) kg/h
Duct width (B)	450...2700mm			
Duct height (H)	450...1650 mm	450...2200 mm	800...3200 mm	800...3200 mm

* For duct widths <600 mm the value in brackets apply

Note: further information on the OptiSorp steam distribution system can be found in the separate manual supplied with the OptiSorp steam distribution system.

3.5.2.3 Blower pack

The blower packs – in combination with the steam humidifiers Condair RS – are used for direct room humidification. The blower packs are mounted directly on the humidifier or separately above the humidifier to the wall.

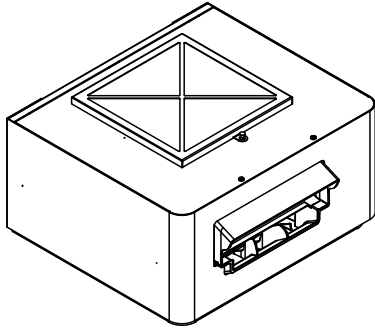

Note: further information on the blower pack can be found in the separate manual supplied with the blower pack.

4 Receiving and storage

4.1 Inspection

After receiving:

- Inspect shipping boxes for damage.
Any damages of the shipping boxes must be reported to the shipping company without delay.
- Check packing slip to ensure all parts has been delivered.
All material shortages are to be reported to your Condair partner within 48 hours after receipt of the goods. Condair Group AG assumes no responsibility for any material shortages beyond this period.
The standard delivery includes:
 - Condair RS steam humidifier equipped with the options ordered according [chapter 3.4](#), packed in cardboard box with:
 - Fastening set
 - Installation manual (this document), operation manual and spare parts list
 - Water drain hose with hose clamp
 - Supply cable between Module A to Module B (for double units and Linkup systems only)
 - Data cable between Module A to Module B (for double units and Linkup systems only)
 - Linkup cable between "Main A" and "Extensio"n"A" (for Linkup systems only)
Note: the supply cable, the data cable and the Linkup cable are supplied in the box of main unit A.
 - Ordered accessories with manual according [chapter 3.5](#), packed separately.
- Unpack the parts/components and check for any damage.
If parts/components are damaged, notify the shipping company immediately.
- Check whether the components are suitable for installation on your site according to the unit data stated on the specification label.

4.2 Storage and Transportation

Storing

Until installation store the Condair RS in its original packaging in a protected area meeting the following requirements:

- Room temperature: 5 ... 40 °C
- Room humidity: 10 ... 75 %rh

Transportation

For optimum protection always transport the unit and components in their original packaging and use appropriate lifting/transporting devices.



WARNING!

It is the customer's responsibility to ensure that operators are trained in handling heavy goods and that the operators comply with the appropriate regulations on work safety and the prevention of accidents.

Packaging

Keep the original packaging of the components for later use.

In case you wish to dispose of the packaging, observe the local regulations on waste disposal. Please recycle packaging where possible.

5 Mounting and installation work

5.1 Safety notes on mounting and installation work

Qualification of personnel

All mounting and installation work must be carried out only by **well qualified personnel authorised by the owner**. It is the owner's responsibility to verify proper qualification of the personnel.

General notes

Strictly observe and comply with all information given in the present installation manual regarding the mounting of the unit and the installation of water, steam and electricity.

Observe and comply with all local regulations dealing with water, steam and electrical installations.

Safety

Some installation work requires removal of the unit covers. Please note the following:



DANGER!
Danger of electric shock!

The Condair RS is mains powered. Live parts may be exposed when the unit is open. Touching live parts may cause severe injury or danger to life.

Prevention: The Condair RS must be connected to the mains only after all mounting and installation work has been completed, all installations have been checked for correct workmanship and the unit is closed and properly locked.



CAUTION!

The electronic components inside the humidifier are very sensitive to electrostatic discharge.

Prevention: To protect these components against damage caused by electrostatic discharge (ESD protection) appropriate measures must be taken when the unit is open for installation work.

5.2 Installation overviews

Typical installation for duct humidification



Abb. 7: Typical installation for duct humidification

Typical installation for room humidification

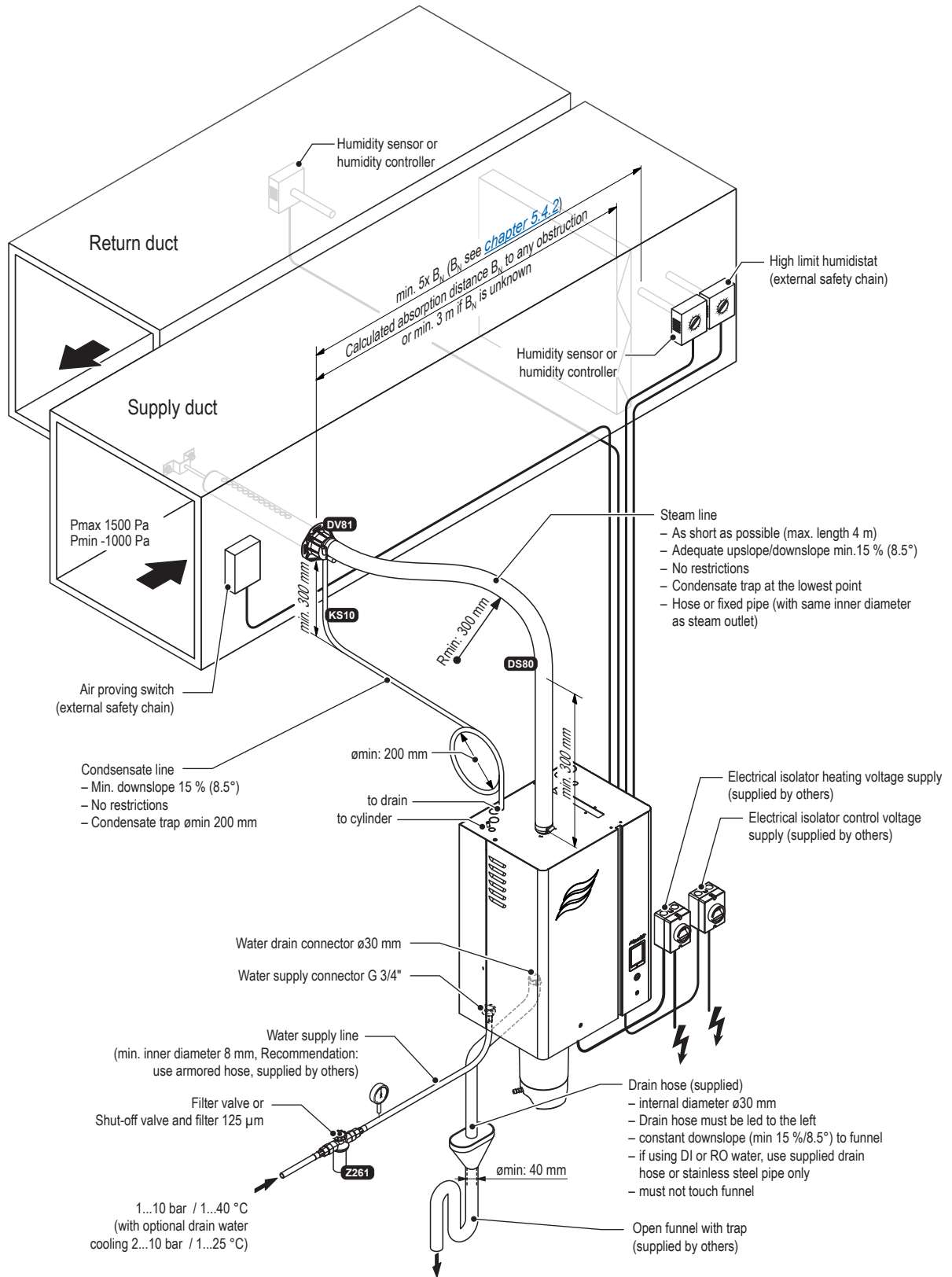

Abb. 8: Typical installation for room humidification

5.3 Mounting the unit

5.3.1 Notes on locating the unit

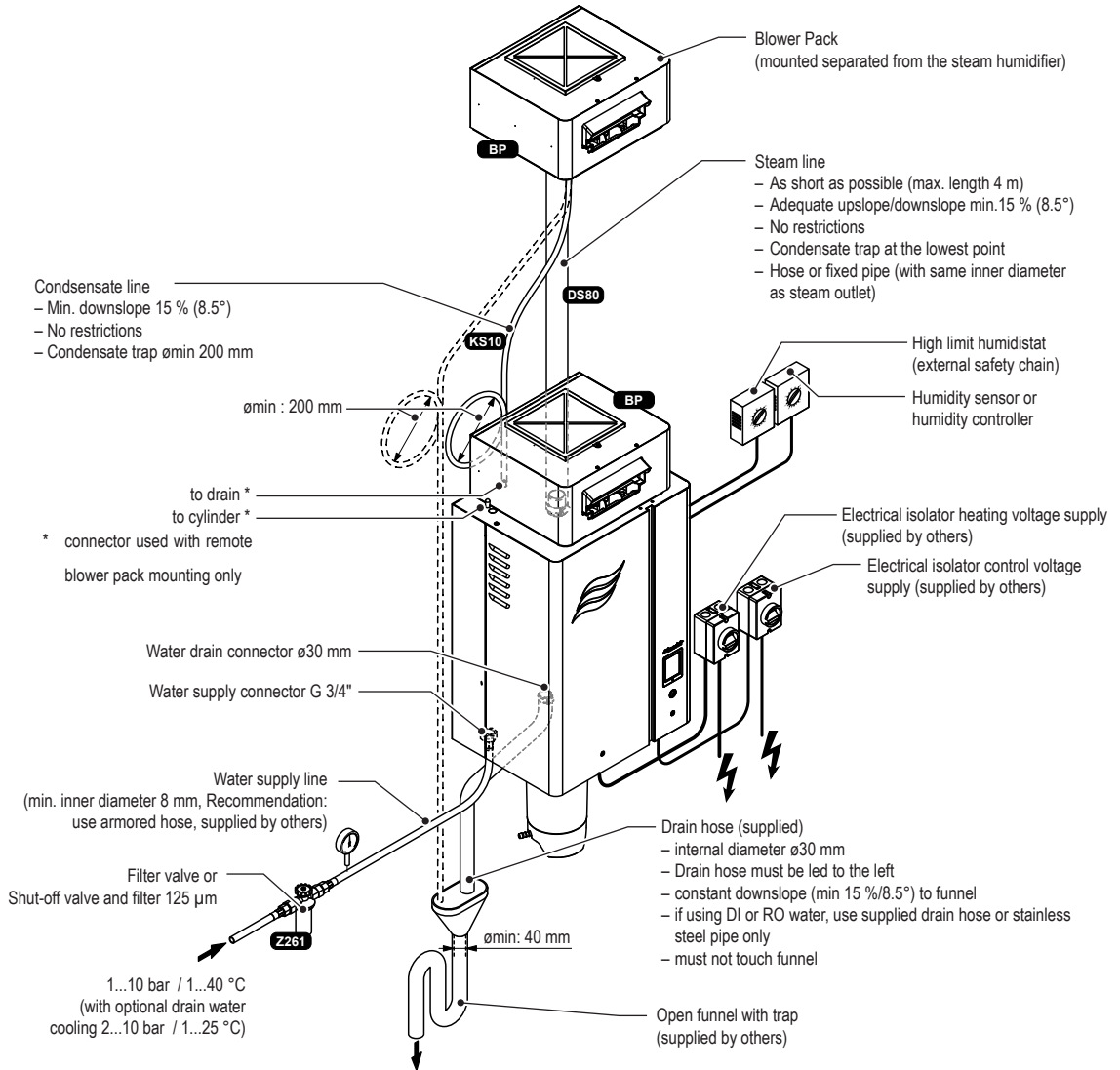

Abb. 9: Distances to be observed

Housing		Small ("S") RS 5 - 10	Medium ("M") RS 16 - 40	Large ("L") RS 50 - 80
			2x, 3x oder 4x "M" RS 50 - 160	
Housing dimensions in mm	X	420	530	1000
	Y	370	406	406
	Z	670	780	780
Netweight in kg		27.2	40.3	81.0
Operating weight in kg		40.2	65.8	132.0

The installation site of the Condair RS depends largely on the location of the steam distributor (see [chapter 5.4.2](#)). To **ensure proper functioning** of the steam humidifier and to **obtain an optimal efficiency**, the following points must be considered and observed when choosing the location for the steam humidifier:

- Install the steam humidifier so that:
 - the **length of the steam** line is kept as short as possible (**max. 4 m**),
 - the **minimum bend radius for steam hoses (R= 300 mm)** and for **solid steam pipes (5 x internal diameter)** and the minimum **upslope** and **downslope (min. 15 %/8.5°)** of the steam lines is maintained (see [chapter 5.4.5](#)).
- The Condair RS is designed for wall-mounting in protected interiors. Make sure that the construction (wall, pillar, floor-mounted console, etc.) to which the humidifier is to be mounted, offers a **sufficiently high load-bearing capacity** (take notice of the weight information found in the dimensions and weights table), and is suitable for the installation.

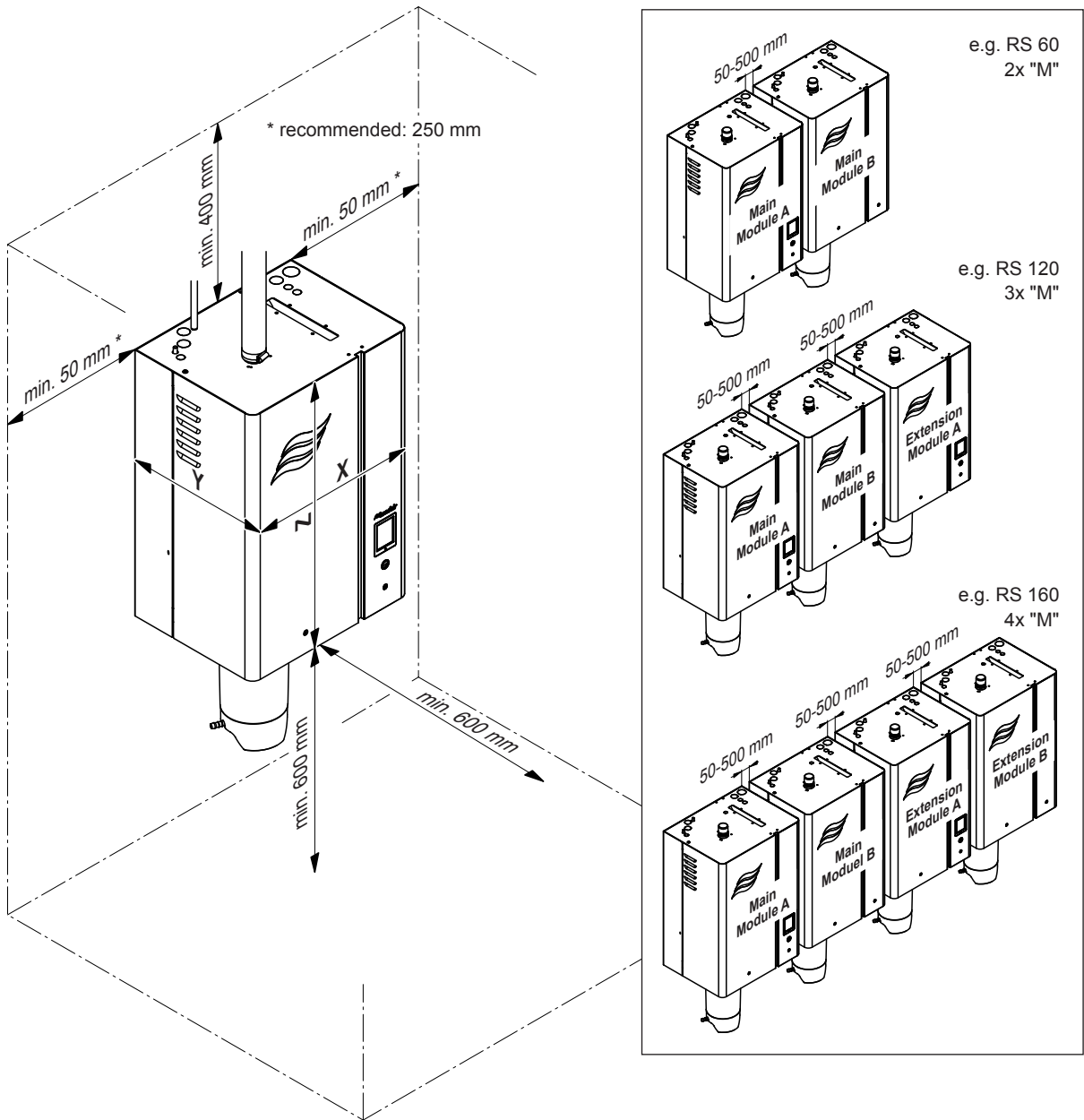

CAUTION!

Do **not** mount the steam humidifier directly to the ventilation duct (insufficient stability).

- The back panel of the Condair RS retains heat during operation (max. surface temperature of the metal housing approx. 60 - 70 °C). Make sure, therefore, that the construction (wall, pillar, etc.) to which the unit is to be mounted, does not consist of heat-sensitive material.
- Install the Condair RS in such a manner that it is **freely accessible** with sufficient space available for maintenance purposes. The **minimum distances** shown in [Abb. 9](#) **must be maintained**.
- In order to use the cables supplied with double units and Linkup systems, the units must be mounted on the same height, with a minimum distance of 50 mm and a maximum distance of 500 mm between the units and in the order shown in [Abb. 9](#).
- The Condair RS is protected according to **IP21**. Make sure the unit is installed in a drip-proof location and the admissible ambient conditions are complied with.
- Do **not** mount the Condair RS to hot or very cold walls or near vibrating components.
- The steam humidifier Condair RS must only be installed in rooms with a floor drain.



CAUTION!

If for some reason the Condair RS must be installed in a location without floor drain, it is mandatory to provide a leakage monitoring device to safely interrupt the water supply in case of leakage.

- When mounting the Condair RS use **only the mounting materials supplied with the unit**. If mounting with the materials supplied is not possible in your particular case, select a method of mounting that is of similar stability.
- The Condair RS is designed for installation and operation within buildings (admissible temperature range 5...40 °C). For outdoor operation the Condair RS must be placed in a weather protective housing. If ambient temperatures near or below the freezing point have to be expected, the protective housing must be equipped with a thermostat controlled heating of sufficient capacity. The water supply pipe must be equipped with a trace-heating and must be insulated up to the protective housing. The installation of a normally open valve inside the building envelope that will drain water in case of power failure is highly recommended

5.3.2 Mounting the humidifier

Overview mounting single units Small and Medium



Abb. 10: Overview mounting single units Small and Medium

Overview mounting single units Large

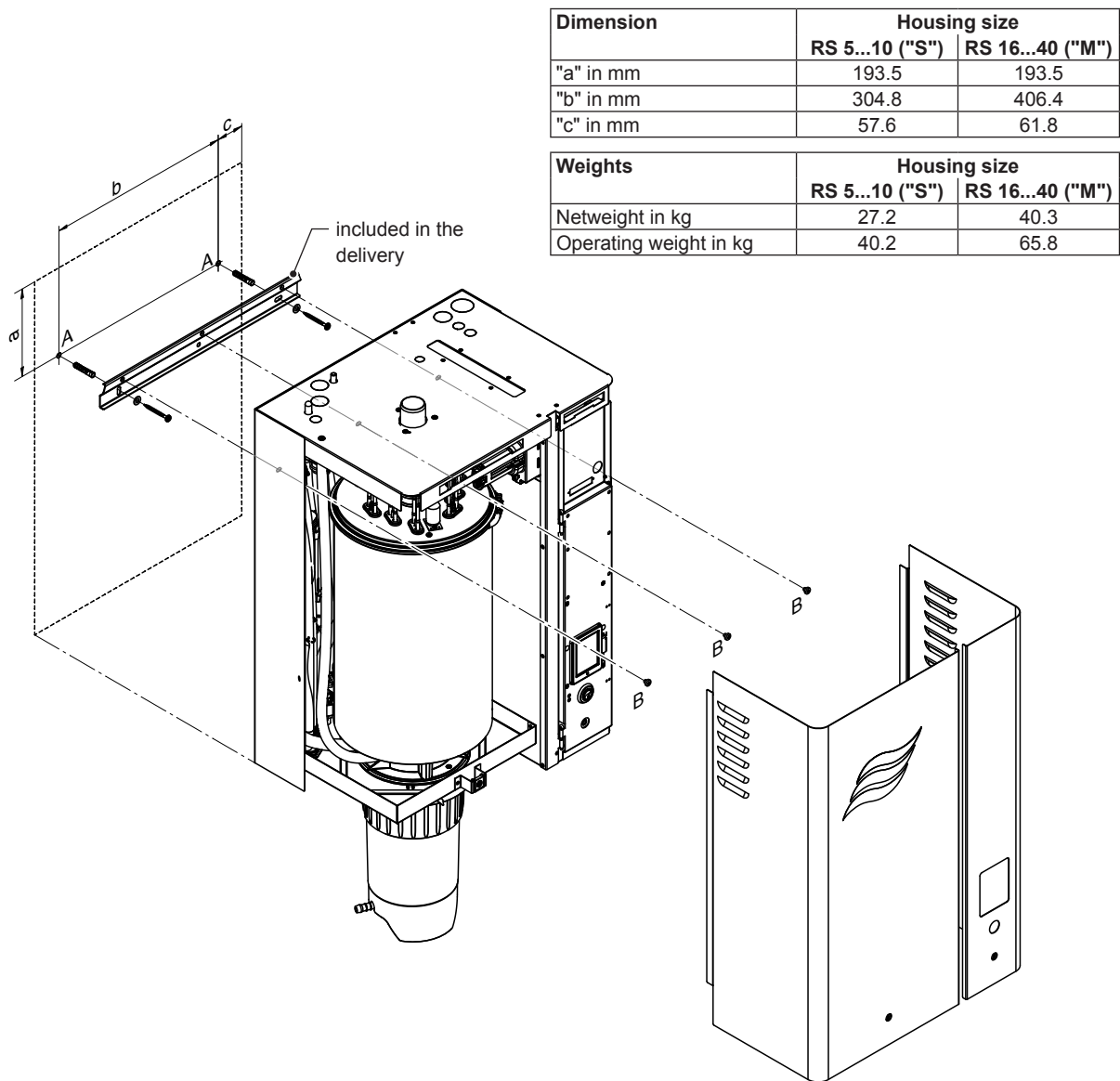

Abb. 11: Overview mounting single units Large

Procedure

1. Mark the attachment points "A" for the mounting rail at the desired position with the help of a spirit level. Then, drill holes diameter: 10 mm, depth: 50 mm.
2. Insert the supplied plastic plugs, and fix the mounting rail to the wall with the screws and washers supplied. Before tightening the screws adjust mounting rail horizontally using a spirit level.
3. Unlock the screw of the front panels, then remove the front panels.
4. Hang up the unit onto the mounting rail. Then, fix the unit to the mounting rail using the supplied screws "B".
5. Reattach the front panels and secure it with the screws.

5.3.3 Inspecting the installed unit

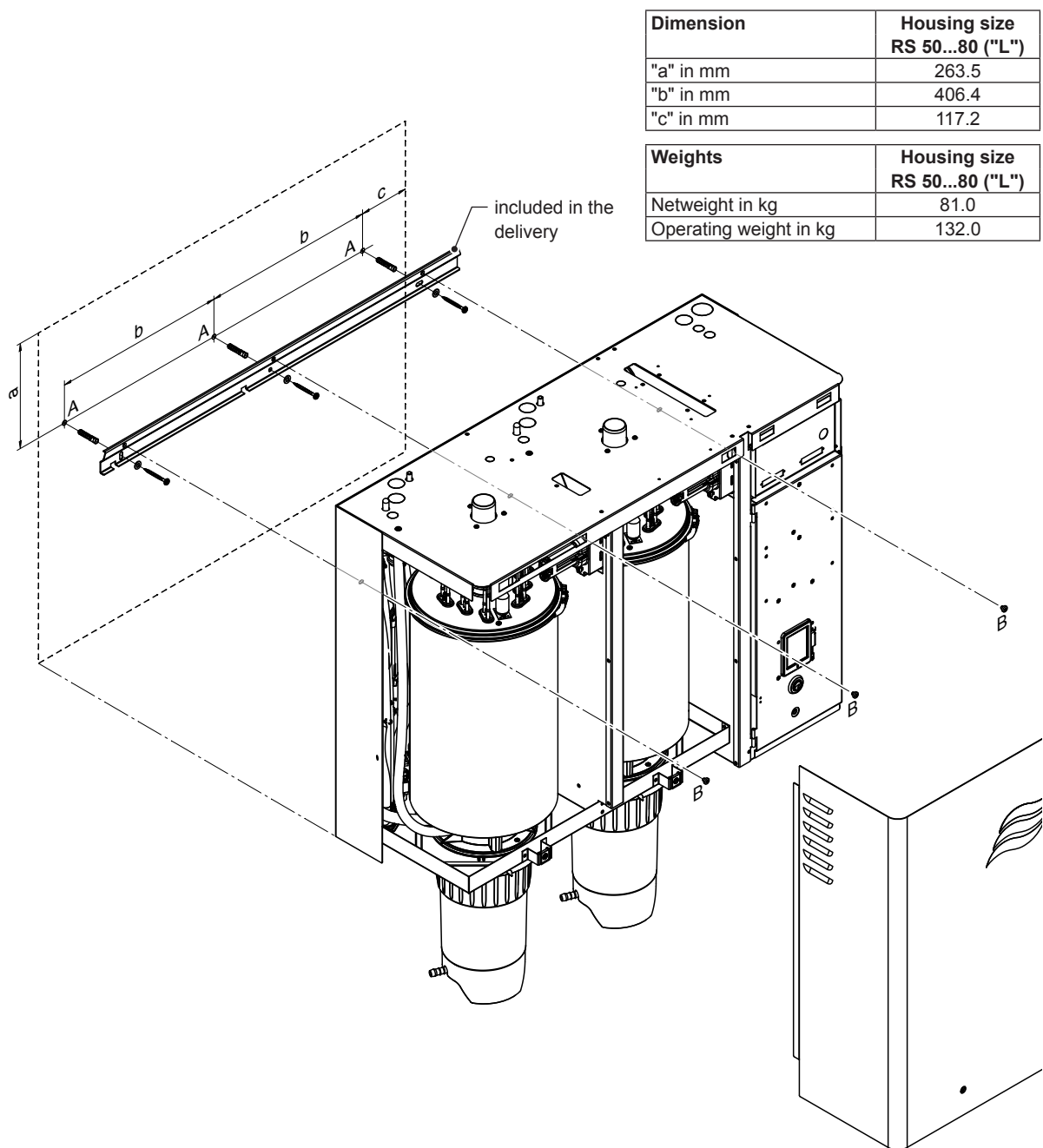
Check the following points:

- Is the unit installed in the correct place (see [chapter 5.3.1](#))?
- Is the supporting surface stable enough?
- Is the unit correctly aligned, vertically and horizontally?
- Is the unit properly secured (see [chapter 5.3.2](#))?

5.4 Steam installation

5.4.1 Overview steam installation for duct humidification



Abb. 12: Overview steam installation for duct humidification



Abb. 13: Overview steam for room humidification

5.4.2 Positioning of the steam distributor

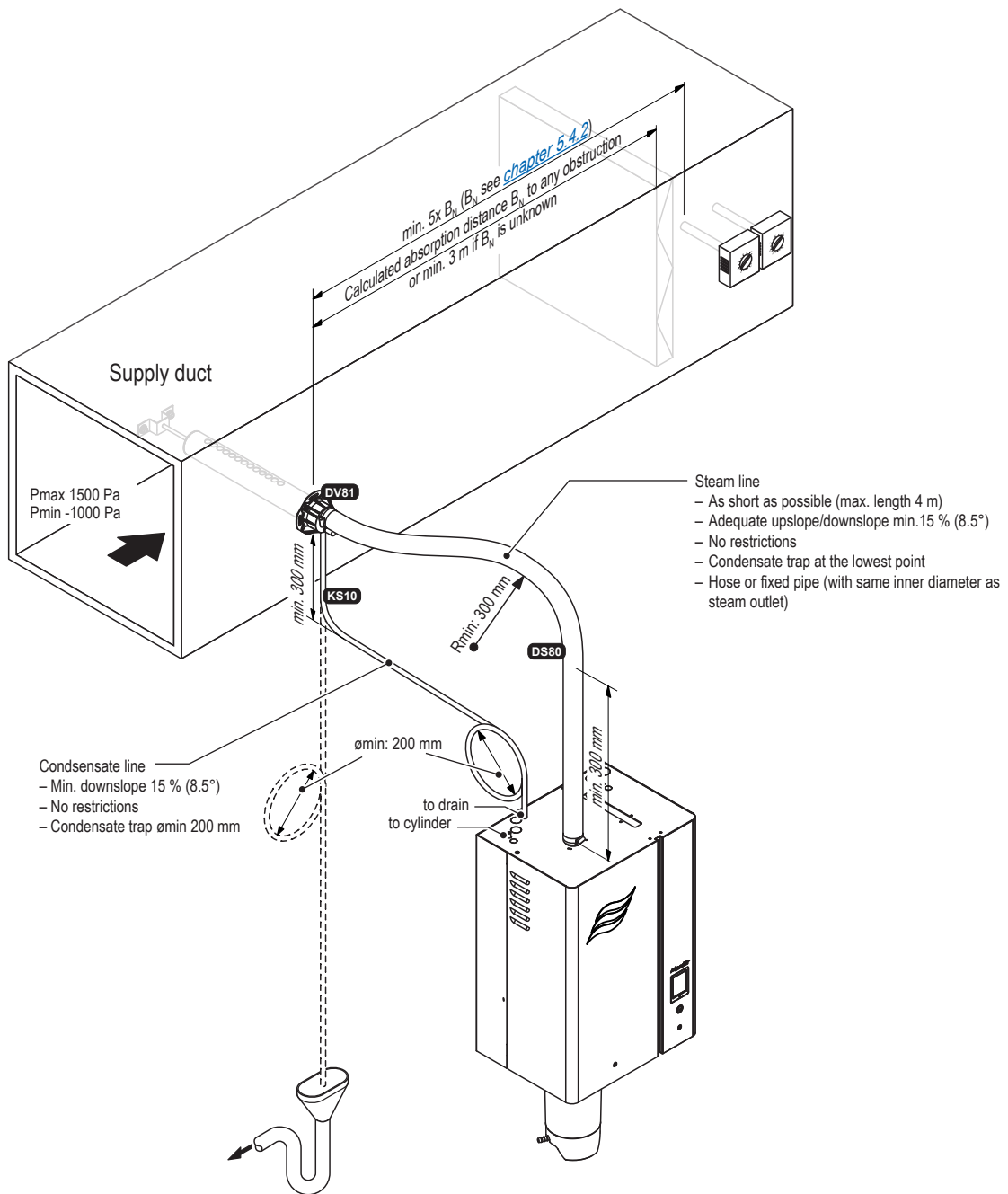
The location of the steam distributor should be determined at the time of dimensioning the air conditioning system. Please note the following instructions to ensure proper humidification of the duct air.

Calculating the absorption distance

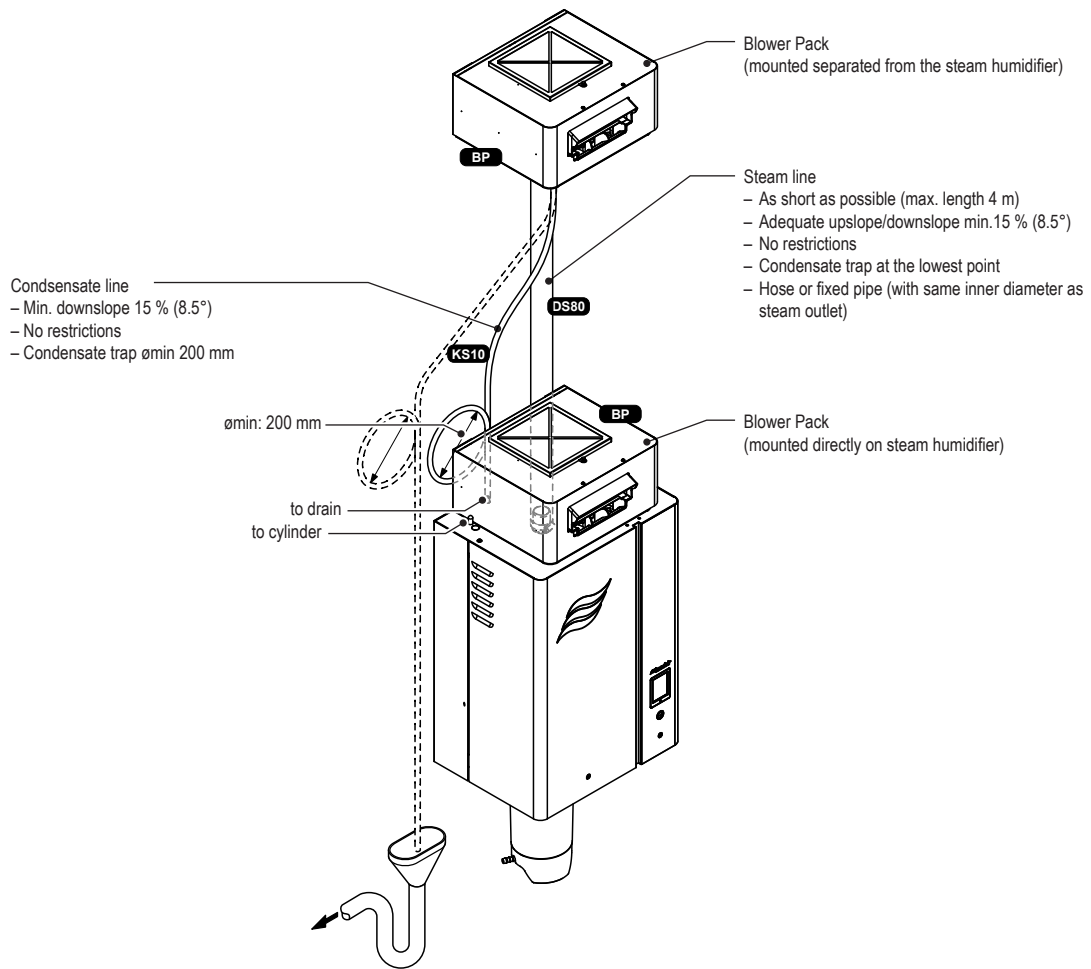
The steam, emitting from the steam distributor, requires a certain distance to be absorbed by the air so that it is no longer visible as steam. This distance is referred to as **absorption distance " B_N "** and serves as a basis for the determination of the minimum distances from the upstream components in the system



Abb. 14: Absorption distance " B_N "

The calculation of the absorption distance " B_N " is dependent on several factors. For a rough estimation of the absorption distance " B_N ", the following table is useful. Recommended standard values listed in this table are based on a supply-air temperature range of 15 °C to 30 °C. The values given in bold type **apply to steam distribution pipes DV81-...**, the values in brackets **apply to the OptiSorp steam distribution system**.

Humidity at inlet ϕ_1 in %rh	Length of absorption distance B_N in m					
	Humidity at outlet ϕ_2 in %rh					
	40	50	60	70	80	90
5	0,9 (0,22)	1,1 (0,28)	1,4 (0,36)	1,8 (0,48)	2,3 (0,66)	3,5 (1,08)
10	0,8 (0,20)	1,0 (0,26)	1,3 (0,34)	1,7 (0,45)	2,2 (0,64)	3,4 (1,04)
20	0,7 (0,16)	0,9 (0,22)	1,2 (0,30)	1,5 (0,41)	2,1 (0,58)	3,2 (0,96)
30	0,5 (0,10)	0,8 (0,17)	1,0 (0,25)	1,4 (0,36)	1,9 (0,52)	2,9 (0,88)
40	–	0,5 (0,11)	0,8 (0,20)	1,2 (0,30)	1,7 (0,45)	2,7 (0,79)
50	–	–	0,5 (0,13)	1,0 (0,24)	1,5 (0,38)	2,4 (0,69)
60	–	–	–	0,7 (0,16)	1,2 (0,30)	2,1 (0,58)
70	–	–	–	–	0,8 (0,20)	1,7 (0,45)

ϕ_1 in %rh: Relative supply air humidity prior to humidification at the lowest supply air temperature
 ϕ_2 in %rh: Relative supply air humidity after the steam distribution pipe at maximum capacity
 For duct widths <600 mm the absorption distance for the OptiSorp system increases by approx. 50%

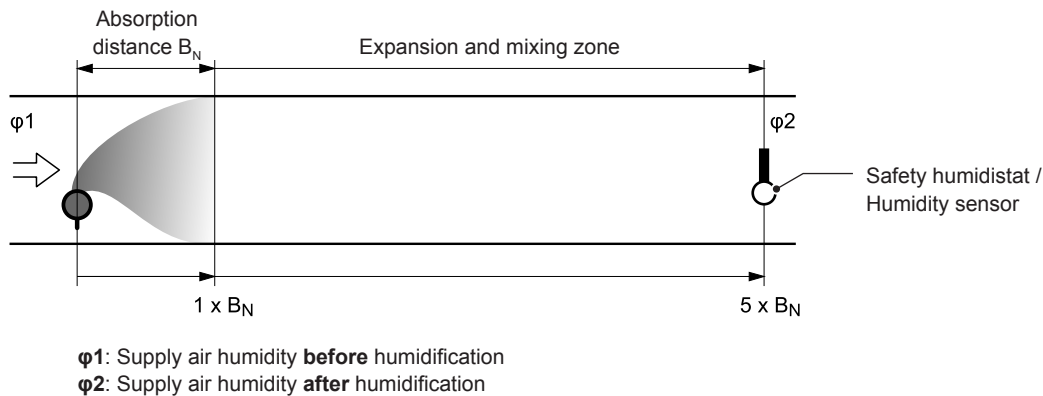
Example

given $\varphi_1 = 30\% \text{rh}$, $\varphi_2 = 70\% \text{rh}$
absorption distance B_N : **1,4 m**
(0.36 m for steam distribution system OptiSorp)

Note: If the absorption distance has to be reduced for technical reasons, the amount of steam per unit must be divided between several steam distribution pipes or the steam distribution system OptiSorp must be used. If this is the case, contact your Condair partner.

Minimum distances to be observed

To prevent the steam, that is emitting from the steam distributor, from condensing on downstream system components, a minimum distance to the steam distributor must be observed (depends on the absorption distance " B_N ").

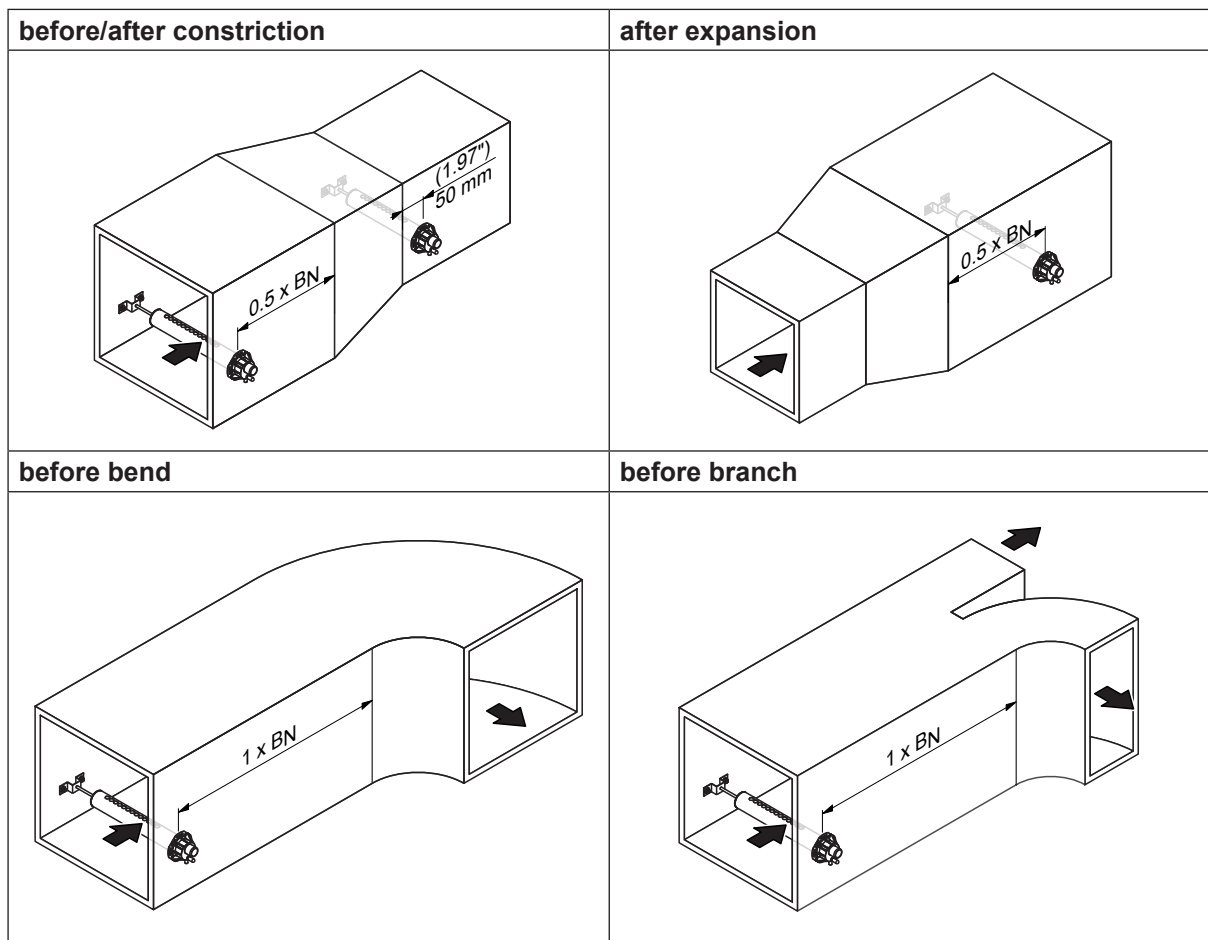

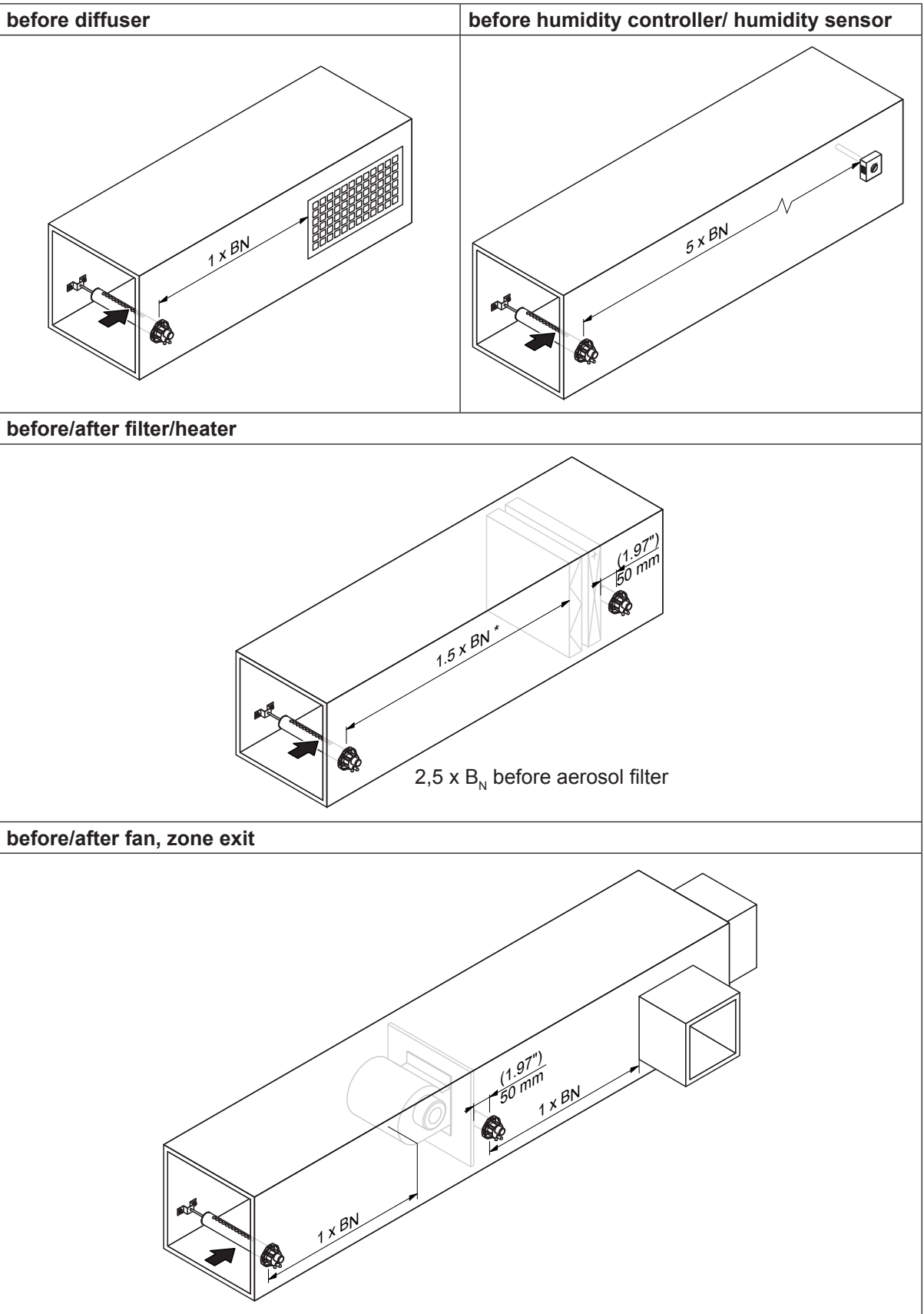

Installation notes

The steam distribution pipes are designed for either **horizontal** installation (on the duct wall) or, with accessories, for **vertical** installation (in the duct floor). The **outlet orifices should always point upwards and at right angles to the airflow**.

If possible, the steam distribution pipes should be installed on the **pressure side** of the duct (**max. duct pressure 1500 Pa**). If the steam distribution pipes are installed on the suction side of the duct, the **maximum vacuum must not exceed 1000 Pa**.

Select a location for the installation, tailored to suit your duct (see the following illustrations) and position the steam distribution pipes in the duct so that a uniform distribution of steam is achieved.

Positioning the steam distribution pipes in the duct

In positioning the steam distribution pipes, the following dimensions should be observed:

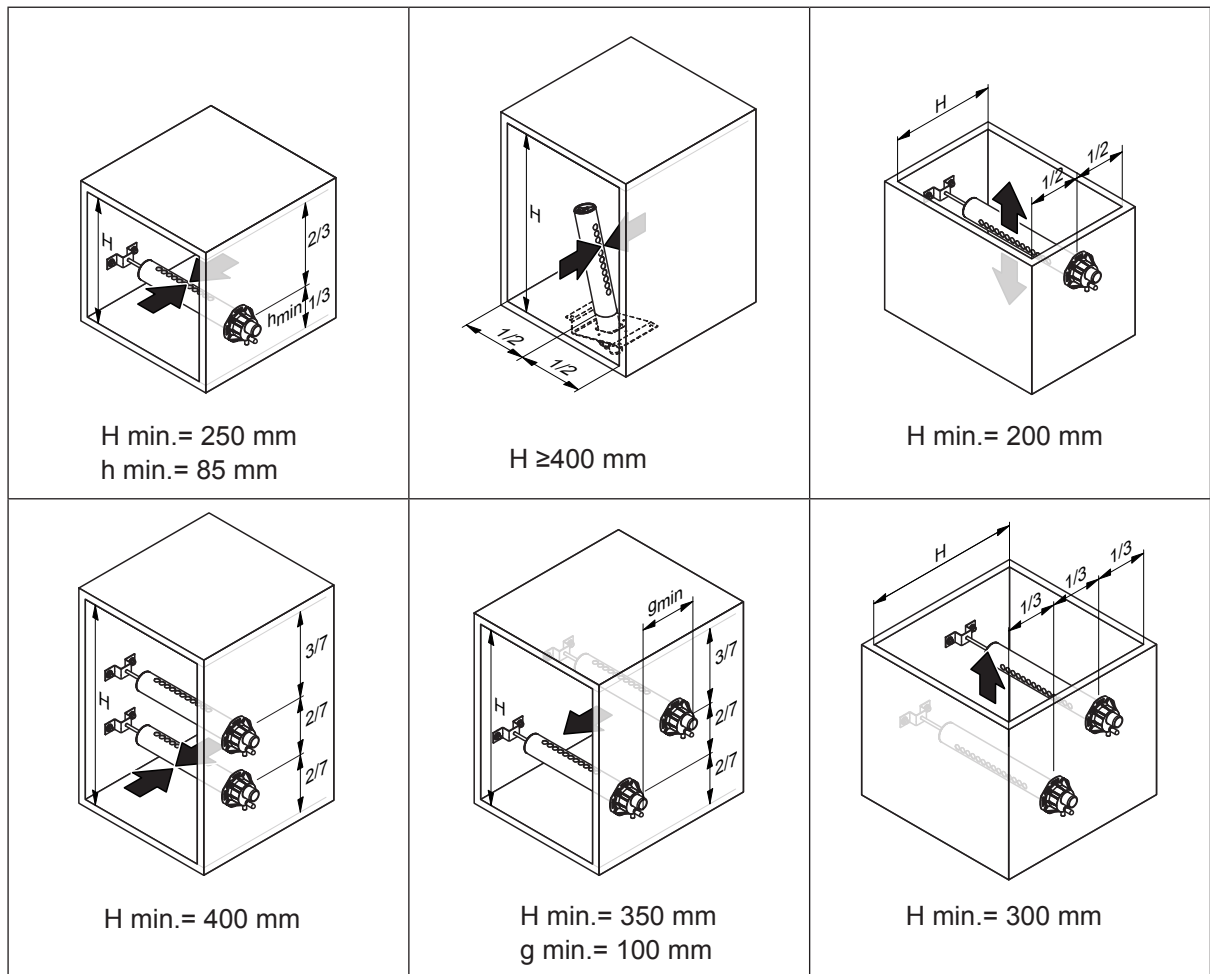

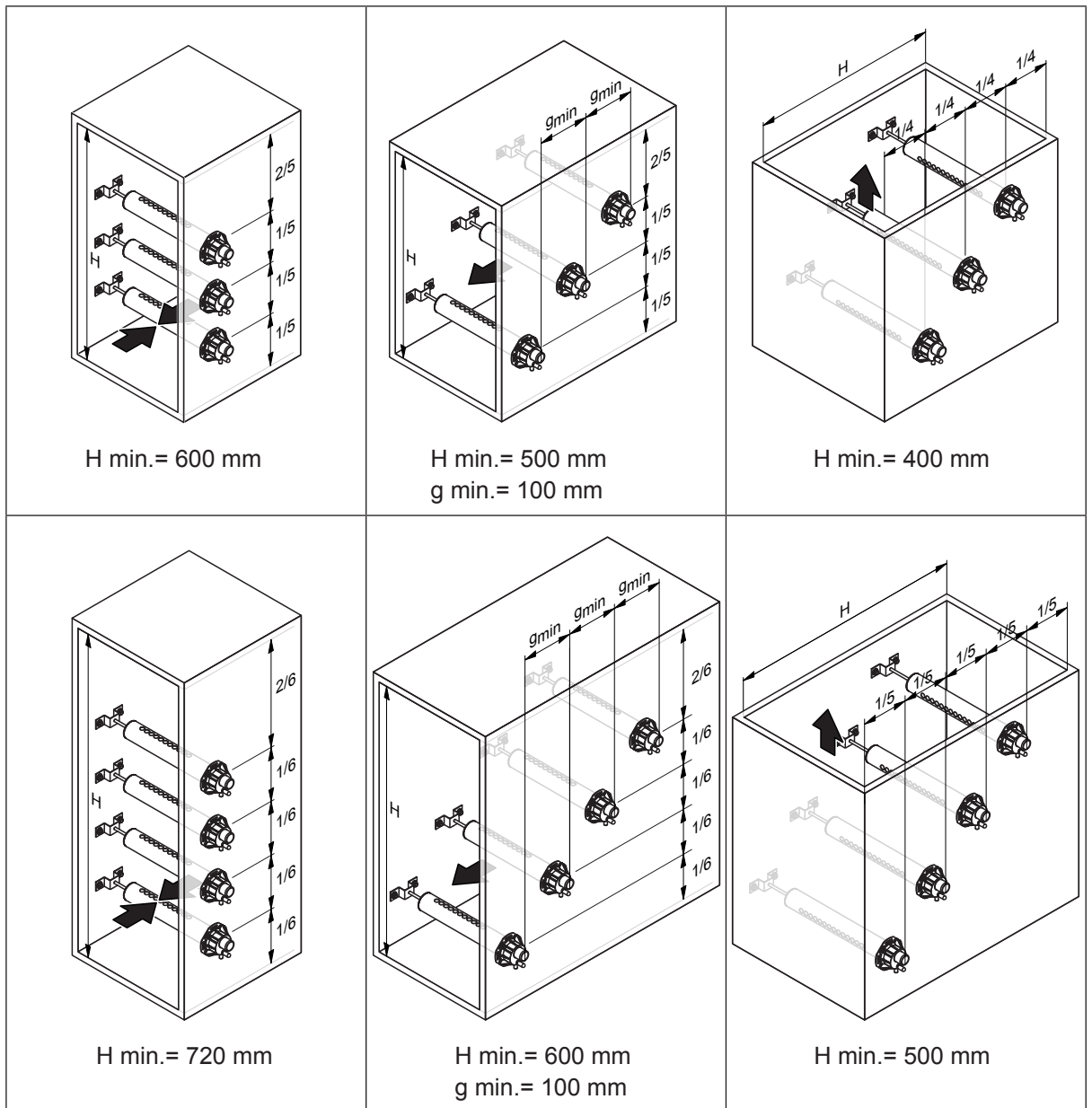

Note: When locating the OptiSorp steam distribution system please note the instructions in the separate documentation for this product.

Guidelines for dimensioning the ventilation ducts

- To facilitate the installation of the steam distribution pipes and for control purposes, a sufficiently sized control opening should be planned.
- Within the range of the absorption distance, the ventilation duct should be waterproofed.
- Air ducts passing through cold rooms should be insulated to prevent the humidified air from condensing along the duct wall.
- Poor airflow conditions within the air duct (e.g. caused by obstacles, tight bends, etc.) can lead to condensation of the humidified air.
- Steam distribution pipes must not be mounted to round ducts.

If you have questions relating to the dimensioning of ventilation ducts in combination with steam humidifiers Condair RS, contact your Condair partner.

5.4.3 Installing the steam distributors

Detailed information on the installation of steam distribution pipes DV81-... and OptiSorp steam distribution system can be found in the separate mounting instructions for these products.

5.4.4 Positioning and mounting of the blower packs (accessory BP)

The blower packs can either be mounted directly on the humidifier or separately above the humidifier to the wall. To allow the steam coming from the blower pack to spread out evenly, without condensing on obstacles (ceilings, joists, pillars, etc.), the following minimum dimensions must be observed when selecting the location for the blower pack.

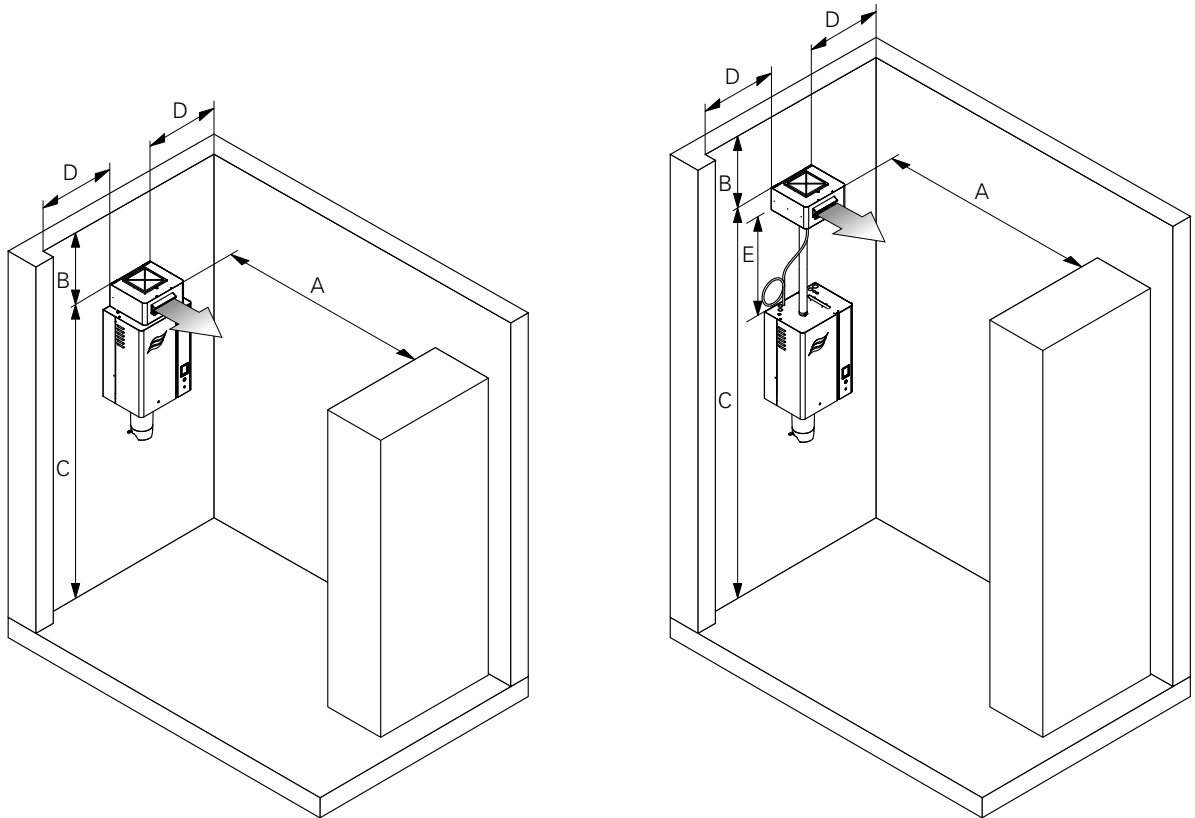

Steam capacity humidifier	kg/h	Fan speed: low				Fan speed: high			
		5...10	>10...20	>20...30	>30...40	5...10	>10...20	>20...30	>30...40
A min.	m	2.5	5.5	8.0	9.5	2.0	3.0	4.5	6.5
B min.	m	0.5	0.5	0.5	1.5	0.5	0.5	0.5	1.0
C min.	m	2.2							
D min.	m	0.5							
E min.	m	1.0							
E max.	m	4.0 (recommended: 2.0)							

Note: The minimum spaces in the table apply for a room atmosphere of 15 °C and 60 %rh. For lower temperatures and/or higher humidity the values should be adjusted accordingly.

Note: In order to achieve a uniform distribution of the humidity within the room, additional factors such as the room size, the room height, etc., must be taken into consideration besides observing the minimum distances for the blower packs. If you have questions concerning the direct room humidification, please contact your Condair partner.

Further information is provided in the separate installation and operating instructions for the corresponding blower pack.

5.4.5 Installing the steam and condensate lines

Installations notes

- Use **original steam and condensate hose** from your Condair partner or **solid steam pipes from copper or stainless steel (min. DIN 1.4301) exclusively**. Steam and condensate lines from other material may cause undesired operational malfunctions.
- Initially, lead the steam line **upright upwards min. 300 mm above the humidifier**. Then lead the steam line with a **minimum upslope** and/or a **minimum downslope of 15 %/8.5°** to the steam distributor.
- The condensate hose from the steam distributor is led down to the humidifier with a **minimum downslope of 15 %/8.5°**, via a condensate trap (**min. hose bend diameter Ø200 mm**) and there it is to be connected to the appropriate connector on top of the unit.
Important! Before putting the unit into operation, the condensate trap of the condensate hose must be filled with water.
- The steam line should be kept as short as possible (**max. 4 m** while observing the **minimum bend radius of 300 mm** (for steam hoses) or **5 x internal diameter** (with solid steam pipes), respectively).
Important! Allowance must be made for a **pressure loss of approx. 100 Pa** per meter steam line and per 90° elbow.
- **Important!** When deciding on the length and layout of steam hoses, it should be noted that steam hoses may become shorter and/or longer depending on temperature and age.
- The steam hose must be secured to the steam distributor and humidifier steam outlet by means of **hose clamps**. Solid steam pipes should be connected to the steam distributor and steam humidifier with short lengths of steam hose secured with hose clamps.
Caution! Do not overtighten the hose clamp on the steam connector of the steam humidifier.
- Steam lines made of solid pipes (copper or stainless steel) must be insulated over the entire length to minimize condensate formation (=loss).



DANGER!

Reducing the cross section or the complete closure of the steam line will cause an excessive increase in pressure in the steam cylinder when the unit is operating and could lead to the risk of scalding accidents. All installations must comply with the following instructions.

- When installing make sure the steam line is open over the entire length and through the whole cross section. Any sealing plugs, adhesive sealing sheets etc. must be removed before connecting the steam pipe. Reductions in cross section by kinking or crushing must be avoided.
- Steam hoses must be prevented from sagging (condensate pockets); if necessary, support steam hose with pipe clamps, trough, or wall brackets, and install a condensate drain at any low points in the steam line.
- It is **not permitted to install a stop valve** (e.g. a manually controlled stop valve, solenoid valve, etc.) in the steam line, due to an inadmissible increase of pressure in the steam cylinder if the valve is closed during the operation.
Note: If for technical reasons a stop valve is to be installed, the pressure relief valve (available as accessory) must be installed in the steam line between steam cylinder and and stop valve for safety reason.

Installation examples



Abb. 15: Steam distributor mounted more than 500 mm above the top edge of the humidifier



Abb. 16: Steam distributor mounted less than 500 mm above the top edge of the humidifier

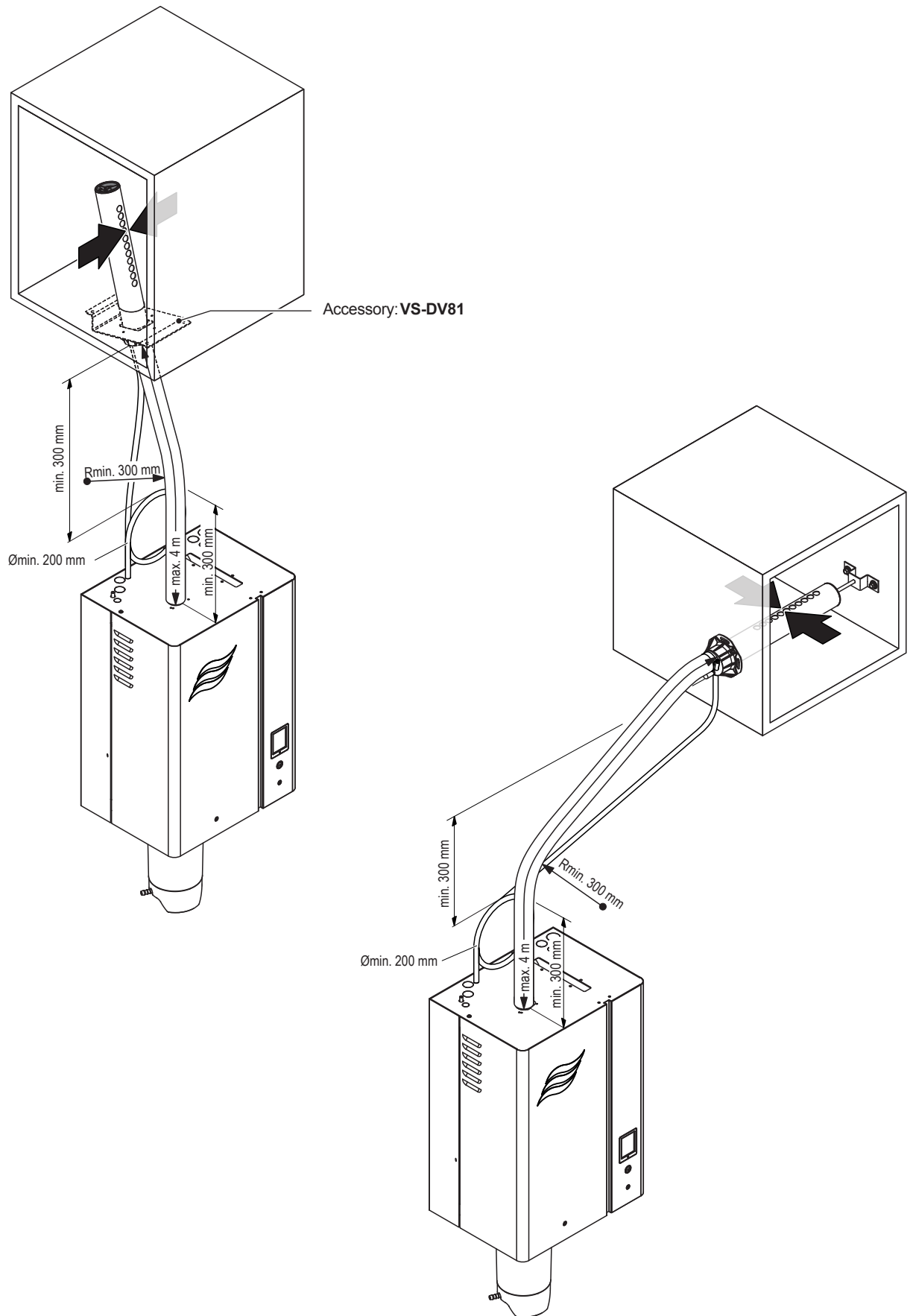

Abb. 17: Steam line with solid piping and insulation

5.4.6 Common steam and condensate line errors

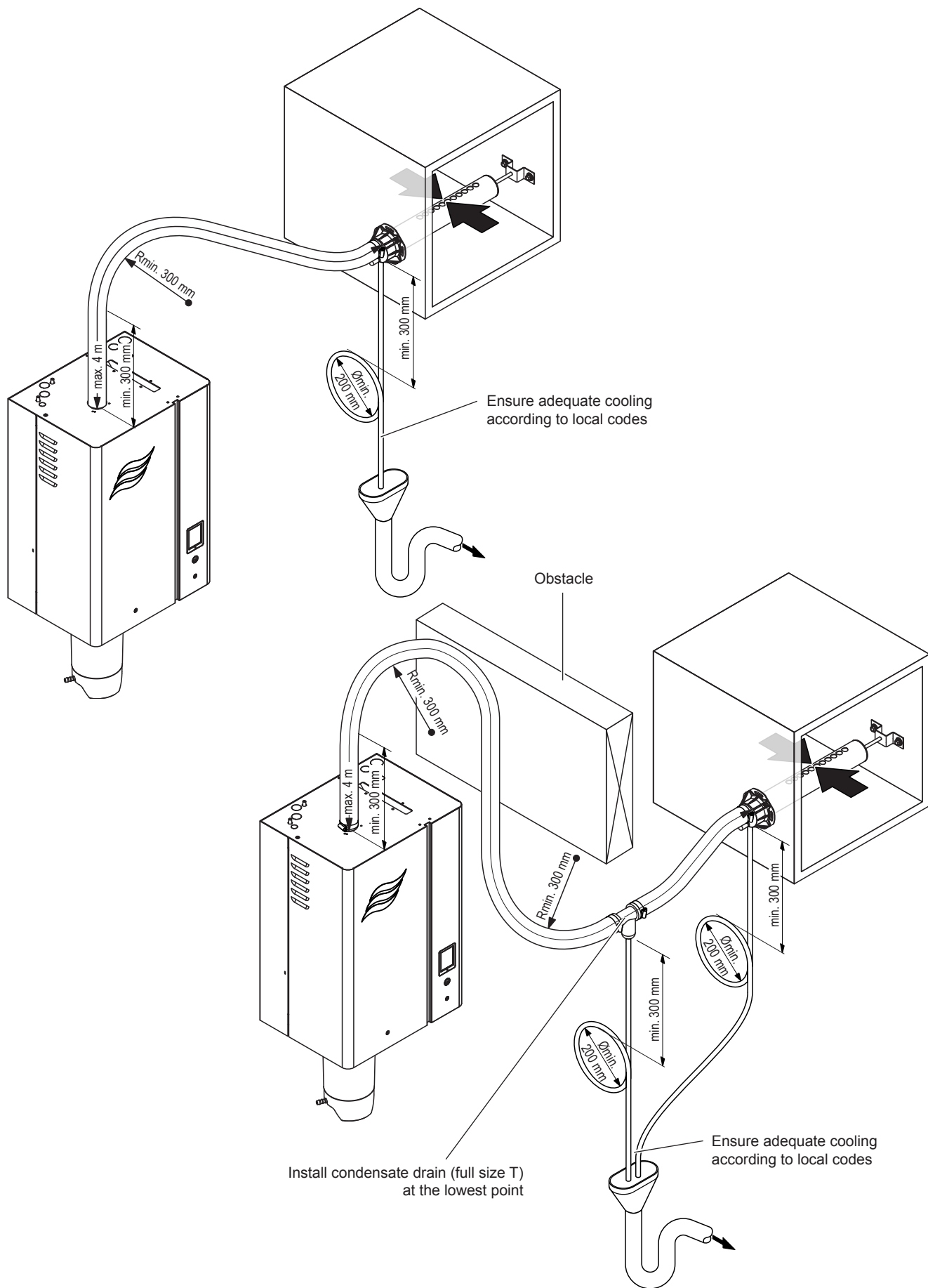

	Wrong	Correct
1	Steam line not led at least 11.81" (300 mm) perpendicularly upwards before first bend (forming of condensate).	Lead steam line at least 11.81" (300 mm) perpendicularly upwards before first bend.
2	Minimum bend radius of steam hose/solid steam line not maintained (forming of condensate).	The minimum bend radius of 11.81" (300 mm) for steam hoses or 5 times steam line internal diameter for solid steam lines must be maintained.
3	Condensate trap not sufficiently high and installed too near at the steam distributor.	The condensate trap must be at least 300 mm below the connector on the steam distributor and it must have a minimum height of 200 mm (ø200 mm).
4	No condensate trap installed at vertical transition.	Install condensate trap at all low points and before vertical transitions.
5	Steam line and condensate hose not sloped (slope min. 20 %).	Install steam line always with constant up or downslope of min. 15 % (8.5°) and condensate hose with constant downslope of min. 15 % (8.5°).

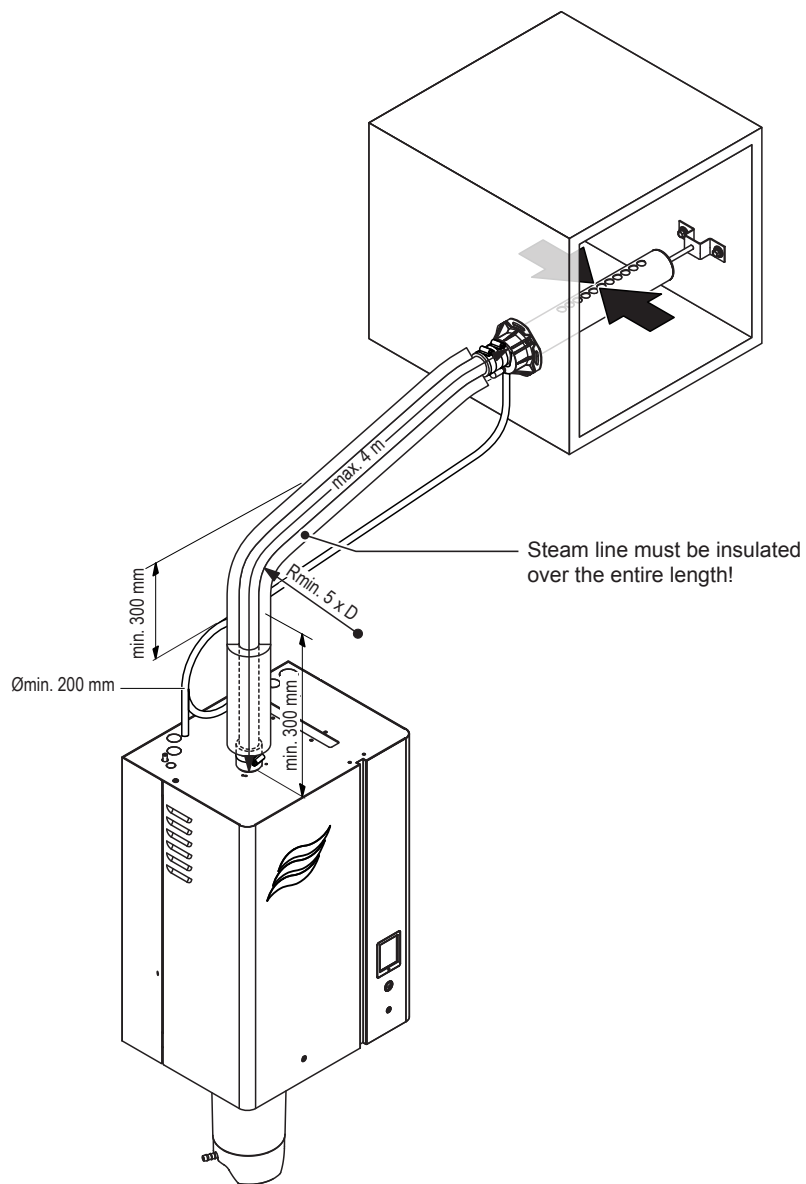
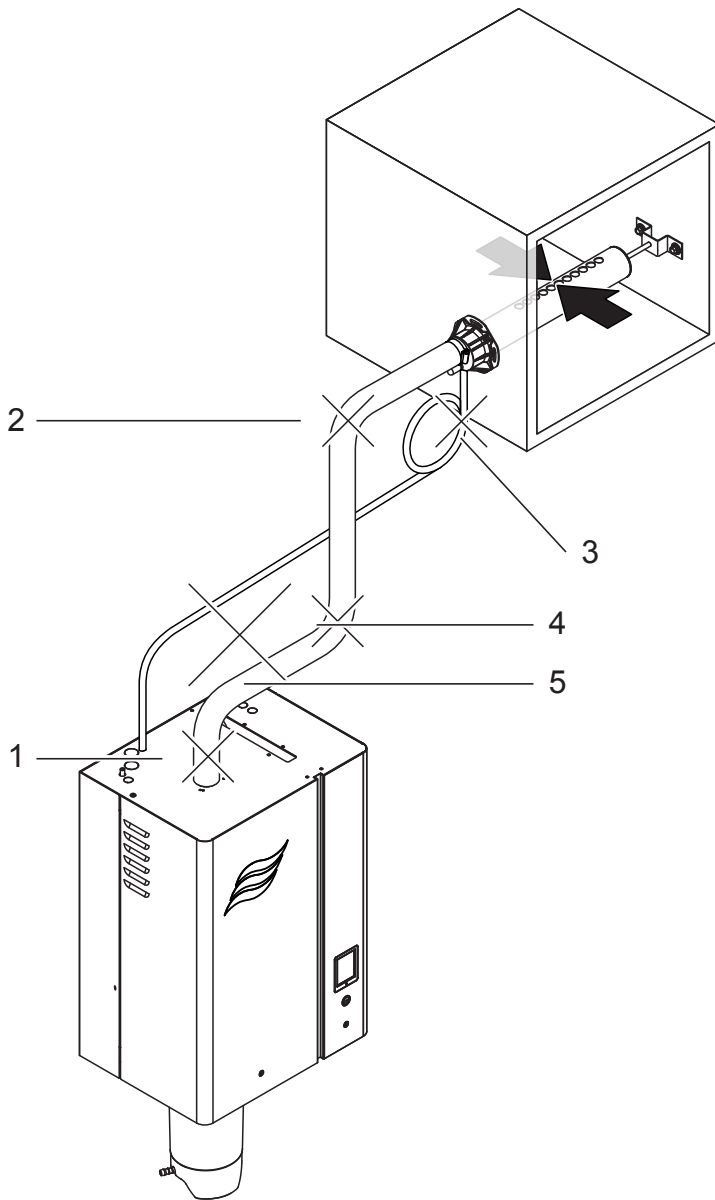
Abb. 18: Common steam and condensate line errors

5.4.7 Inspecting the steam installation

Use the following check list to ensure that the steam installation was performed correctly:

- Steam distributor
 - Steam distributors (steam distribution pipe or OptiSorp steam distribution system) correctly positioned and secured (screws tightened)? Are the outlet orifices at right angles to the air flow for horizontal installation, or at 45 degree angle for vertical installation?
- Steam hose
 - Maximum length of 4 m?
 - Minimum bend radius of 300 mm (5 x internal diameter with fixed piping)?
 - Have the instructions for hose layout been followed?
 - Steam hose: no sagging (condensate pocket) or condensate drain with trap (hose bend with a minimum diameter of 200 mm) installed at the lowest point?
 - Fixed steam lines: properly insulated? Correct installation material used? Minimum internal diameter maintained?
 - Steam hose or steam hose pieces securely attached with clamps?
 - Heat expansion during operation and shortening of the hose with ageing taken into consideration?
- Condensate hose
 - Downslope of at least 20 %?
 - Trap (min. \varnothing 200 mm) in place and filled with water?
 - Condensate hose correctly connected and supported and not kinked?

5.5 Water installation

5.5.1 Overview water installation



Abb. 19: Overview water installation for single units Small ("S") and Medium ("M")



Abb. 20: Overview water installation for single units Large ("L")

5.5.2 Notes on water installation

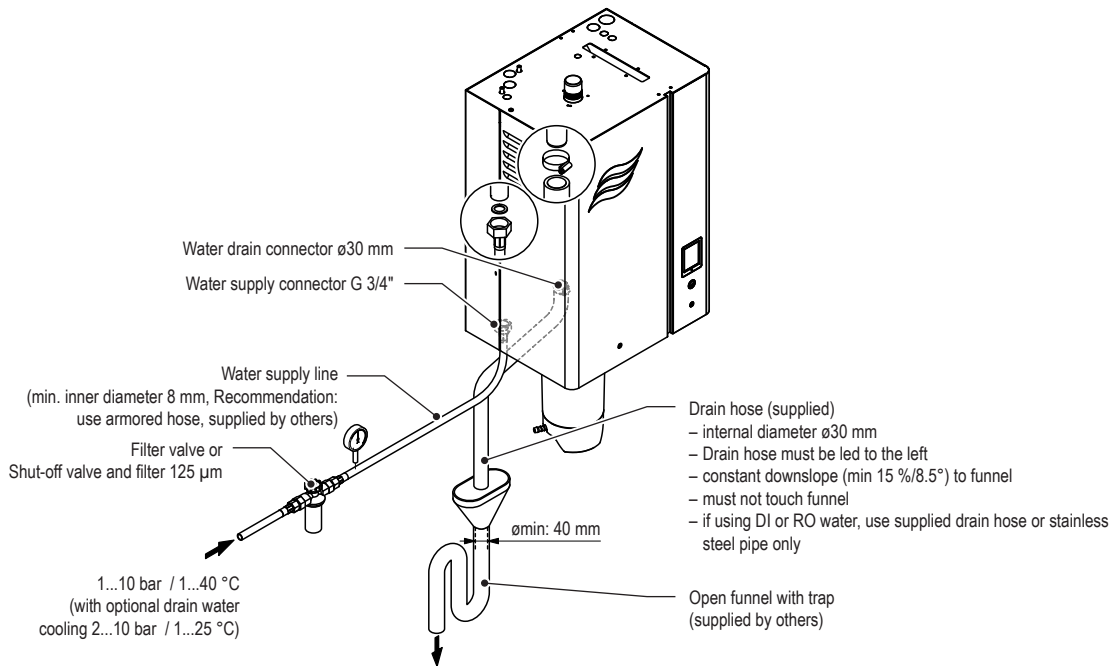
Water supply

The water supply is to be carried out according to the figure found in [chapter 5.5.1](#) and the applicable local regulations for water installations. The indicated connection specifications must be observed.

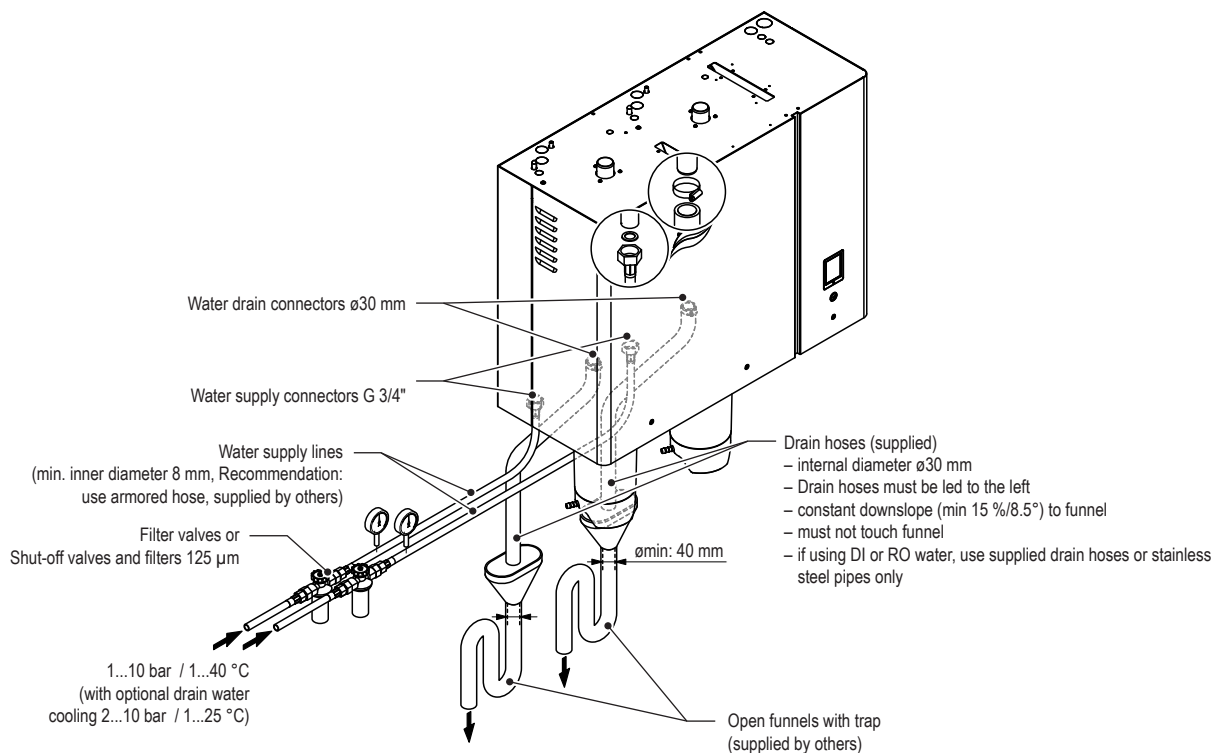
- The installation of the **filter valve** (accessory "Z261", alternatively a shut-off valve and a 125 µm water filter can be used) should be made as close as possible to the steam humidifier.
Note: on large units with two steam cylinders, on double units and on Linkup systems each unit must be connected separately via a filter valve (or shut-off valve and water filter) to the water supply.
- Admissible water supply pressure:
 - **1.0...10.0 bar** (units **without** drain water cooling)
 - **2.0...10.0 bar** (units **with** drain water cooling)

Note: For mains pressures >10 bar, the connection must be made via a pressure reducing valve (adjusted to 2.0 bar). For mains pressures <1.0 bar (units **without** drain water cooling) <2.0 bar (units **with** drain water cooling) please contact your Condair supplier.

Note: The water supply system must be free of pressure bumps (**hammer-free**). The installation of a check valve in the water supply line is therefore not permitted, as this can lead to pressure bumps in the water system and damage the inlet valve. If a pipe disconnecter is to be installed in the inlet water system, a model with overpressure protection must be installed. If water hammers cannot be avoided in the supply line, a pressure shock absorber must be installed.

- Supply rate: 1 l/min per 15 kg/h steam capacity
- **Notes on water quality:**
 - For the water supply of the Condair RS, use exclusively **untreated drinking water in accordance with the applicable local regulations**, water from a RO system or de-ionized water.
Note: For highly corrosive water (conductivity <1 µS/cm, chloride content >30 mg/l) we recommend using the special steam cylinder with nickel-plated heating elements (UPW option).
 - The use of **additives** such as corrosion inhibitors, disinfectants, etc. is **not allowed**, since these additives may endanger health and affect proper operation.
- The connection material must be **pressure-proof** and **certified for use in drinking water systems**.
- The water supply line(s) must be fastened with suitable means.
- **Important!** Before connecting the water line, **the line must be well flushed out**.



CAUTION!

The thread at the humidifier connection is made of plastic. To avoid overtightening, the union nut of the water pipe must be **tightened by hand** only.

Water drain

The water drain is to be carried out according to the figures found in [chapter 5.5.1](#) and the applicable local regulations for water installations. The indicated connection specifications must be observed.

- Draining rates:

Note: The draining rates shown in the table below apply to the operation of the Condair RS with untreated drinking water and the factory settings for the water reduction interval time. When operating with reverse osmosis or deionized water, the water reduction interval time can be reduced according to the table in the operation manual, which reduces the draining rate accordingly.

Condair	Steam capacity (kg/h)	Diameter steam cylinder (mm)	Water reduction interval time (min)	Draining rate without drain water cooling (l/h)	Draining rate with drain water cooling (l/h)
RS 5	5	200	30	1.2	1.9
RS 8	8	200	20	1.8	2.8
RS 10	10	200	20	1.8	2.8
RS 16	16	280	10	4.8	7.6
RS 20	20	280	7	6.9	10.9
RS 24	24	280	7	6.9	10.9
RS 30	30	280	5	9.6	15.2
RS 40	40	280	5	9.6	15.2

- The draining temperature is: 80...90 °C (with optional drain water cooling <60°C). Use temperature-resistant installation materials only!
- Make sure that the drain pipes, the funnel(s) and the siphon(s) are correctly fixed and easily accessible for inspections and cleaning purposes.
- Always lead the supplied drain hose from the connector to the left down to the funnel (see [Abb. 19](#)).
On large units with two steam cylinders each drain line must be led into a separate funnel with trap (see [Abb. 20](#)).
On double units each drain hose must be led into a separate drain funnel. It is important to ensure that the drain funnels are not placed under the steam humidifiers in order to prevent damage to the devices from rising steam.
- Attach drain line(s) in such a way, that it/they cannot slip out of the funnel(s) and that it/they cannot bottom out in the funnel(s).
- The open end of the drain line(s) must not touch the funnel(s) (min. air gap 2 cm).

5.5.3 Inspecting the water installation

Check the following topics:

- Water supply
 - Has filter valve (accessory "Z261") or shut-off valve and 125 µm water filter respectively been installed in supply line to each unit module?
 - Has acceptable water pressure (without drain water cooling: 1 – 10 bar, with drain water cooling: 2 – 10 bar) and acceptable water temperature (without drain water cooling: 1 – 40 °C, with drain water cooling: 1 – 25 °C) been connected?
 - Does the water supply capacity match the humidifier and is the minimum inside diameter of 8 mm of the supply pipe maintained throughout the entire length (min. internal diameter of 12 mm for systems with optional drain water cooling recommended)?
 - Are all components and pipes properly secured and are all threaded connections securely tightened?
 - Is the water system properly sealed?
 - Does the water supply installation meet the requirements of the local regulations for water installations?
- Water drain
 - Is the minimum inside diameter of the drain pipe(s) of 30 mm maintained throughout the entire length?
 - Has/have drain pipe(s) been installed with a downslope of at least 15 %/8.5°?
 - Has the heat resistance of the material used been verified to be at least 100 °C (60 °C for systems with optional drain water cooling)?
 - Is/are the drain hose(s) properly secured (hose clamps at unit connection tightened)?
 - Is there an air gap (min 2 cm) between the open end of the drain line and the funnel?
 - Does the water drain installation meet the requirements of the local regulations for water installations?

5.6 Notes on humidity control systems/humidity control

5.6.1 System 1 – Room humidity control

System 1 is suited for **direct room humidification** and **air conditioning systems with mainly recirculated air**. The humidity sensor or humidistat respectively is preferably located in the room itself or in the exhaust air duct.



Abb. 21: System 1 – Room humidity control

5.6.2 System 2 – Room humidity control with continuous limitation of the supply air humidity

System 2 is suited for air conditioning systems with a **large portion of supply air**, **low supply air temperature**, **post-humidification**, or **variable airflow volume**. If the supply air humidity exceeds the preset value, the continuous limitation is effected prior to the room humidity control.

The humidity sensor (A1) is preferably located in the exhaust air duct or in the room itself. The humidity sensor (A4) for the limitation of the supply air humidity is located in the supply air duct after the steam distribution pipe. This control system requires a continuous controller with the option to connect a second humidity sensor.

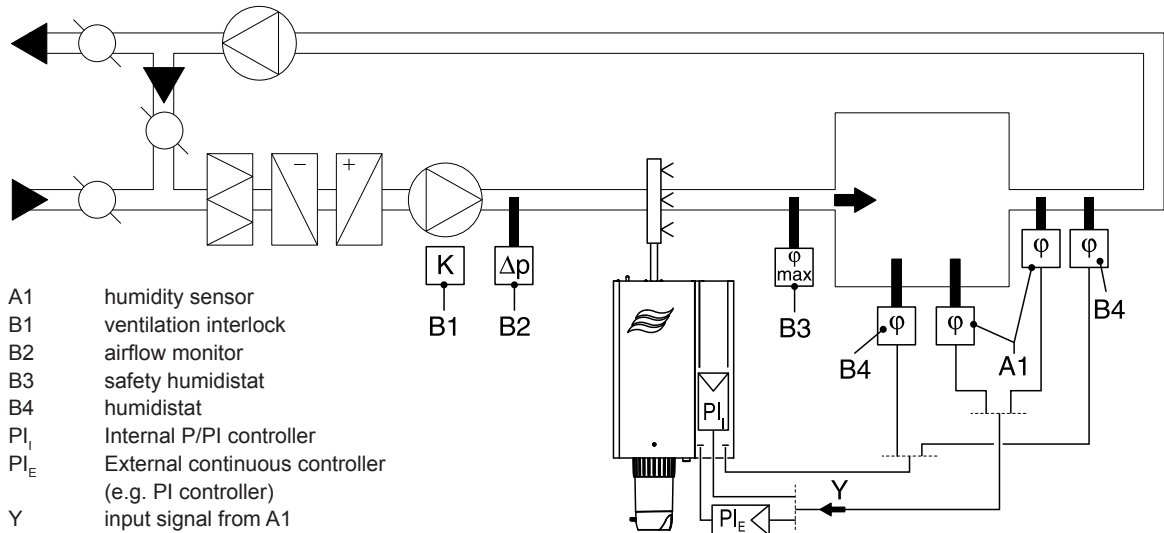
Attention! The continuous limitation of the supply air humidity is no substitute for the safety humidistat.



Abb. 22: System 2 – Room humidity control with continuous limitation of the supply air humidity

5.6.3 System 3 – Supply air humidity control with continuous output limitation

Supply air humidity control (humidity sensor installed in supply air duct) should be used only where room humidity control is impracticable for technical reasons. Such systems always require a PI-controller.

The humidity sensor (A1) is located in the supply air duct after the steam distribution pipe. The humidity sensor (A4) for the continuous output limitation is located in the supply air duct before the steam distribution pipe. Such a system requires a PI-controller with the option to connect a second humidity sensor.

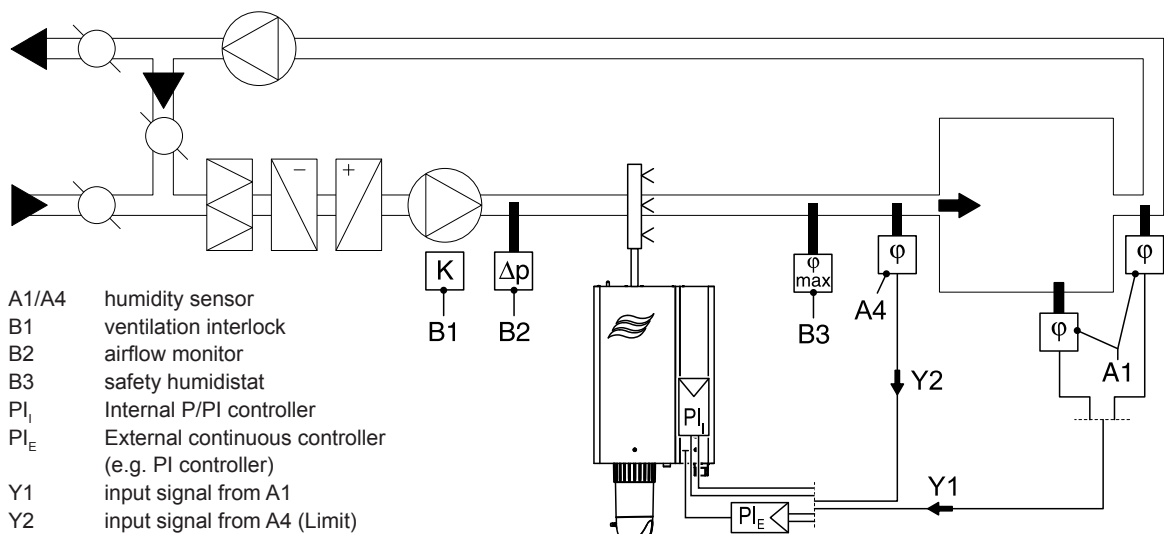

Abb. 23: System 3 – Supply air humidity control with continuous output limitation

5.6.4 Which humidity control system for which application

Application	Location of the humidity sensor	
	room or exhaust air duct	supply air duct
Air conditioning systems with:		
– supply air portion up to 33%	System 1	System 1
– supply air portion up to 66%	System 1 or 2	System 2 or 3
– supply air portion up to 100%	System 2	System 3
– supply air humidity control	—	System 3
Direct room humidification	System 1	—

Please contact your Condair partner, if your application meets the following conditions:

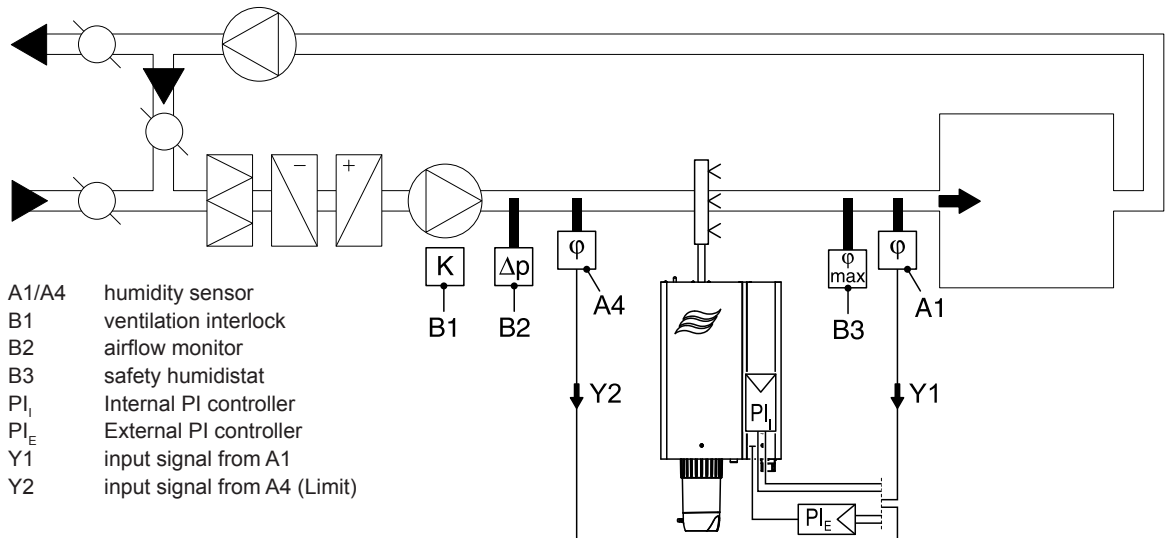
- Humidification of small rooms up to 200 m³
- Air conditioning systems with a high number of air exchanges
- Systems with variable air volume flow
- Test facilities with extreme control accuracy requirements
- Rooms with a high variation in max. steam capacity
- Systems with temperature fluctuations
- Cold rooms and systems with dehumidification

5.6.5 Admissible control signals

Control with external controller Control signals	Control with internal PI controller Humidity sensor signals
0...5 VDC	0...5 VDC
1...5 VDC	1...5 VDC
0...10 VDC (Potentiometer 140 Ω ... 10 kΩ)	0...10 VDC (Potentiometer 140 Ω ... 10 kΩ)
2...10 VDC	2...10 VDC
0...20 VDC	0...20 VDC
0...16 VDC	0...16 VDC
3.2...16 VDC	3.2...16 VDC
0 ... 20 mA	0 ... 20 mA
4 ... 20 mA	4 ... 20 mA
Humidistat (24 V On/Off)	

5.7 Electrical installation

5.7.1 Notes on electrical installation



DANGER!
Danger of electric shock

The Condair RS is mains powered. Live parts may be exposed when the unit is open. Touching live parts may cause severe injury or danger to life.

Prevention: The Condair RS unit must be connected to the mains only after all mounting and installation work has been completed, all installations have been checked for correct workmanship and the unit is closed and properly locked.



CAUTION!

The electronic components inside the unit are very sensitive to electrostatic discharge. Before carrying out installations work inside the unit, appropriate measures must be taken to protect the electronic components against damage caused by electrostatic discharge (ESD protection).

- All work concerning the electrical installation must be performed only by **skilled and qualified technical personnel (e.g. electrician with appropriate training) authorised by the owner**. It is the owner's responsibility to verify proper qualification of the personnel.
- The electrical installation must be carried out according to the corresponding wiring diagram (see [chapters 5.7.2/5.7.3/5.7.4/5.7.5](#)), the notes on electrical installation as well as the applicable local regulations. All information given in the wiring diagrams and notes must be followed and observed.
- All cables must be lead into the unit, via appropriate cable strain relief or grommets. The cable for the heating voltage supply must be lead into the unit from the bottom via the cable opening equipped with the clamp. Fix the cable with the clamp strap.
- Make sure the cables are adequately clamped, do not rub on any components or become a tripping hazard.
- Observe and maintain maximum cable length and required cross section per wire according to local regulations.
- The mains supply voltages (heating and control voltage supply) must match the respective voltage stated on the specification label.

5.7.2 Wiring diagram Condair RS - Single units "S" and "M" (5...40 kg/h)



Abb. 24: Wiring diagram Condair RS - Single units "S" and "M" (5...40 kg/h)

5.7.3 Wiring diagram Condair RS - Single units "L" 50...80 kg/h (double housing)

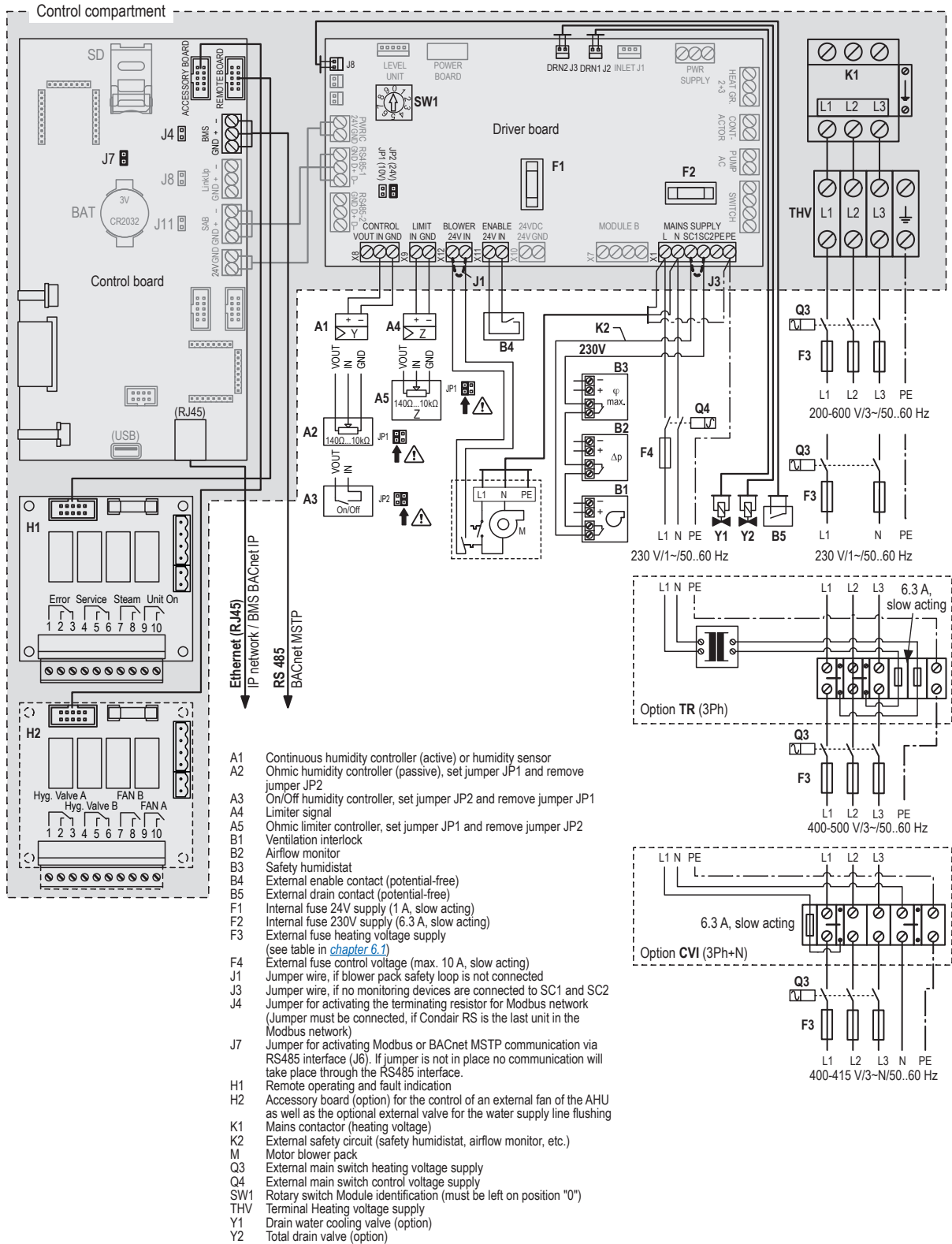

Abb. 25: Wiring diagram Condair RS - Single units "L" 50...80 kg/h

5.7.4 Wiring diagram Condair RS - Double units (2 x single housings "M") 40...80 kg/h

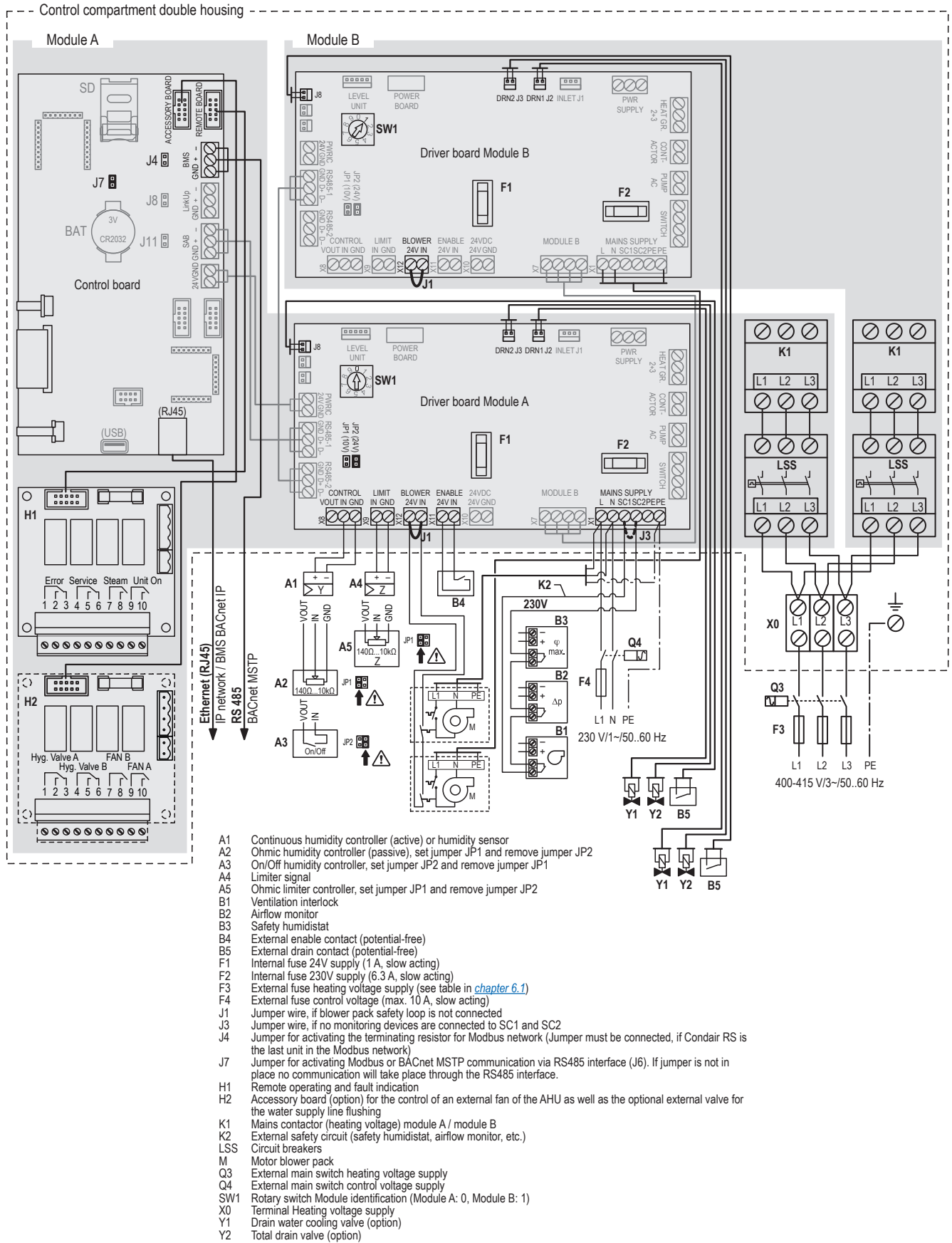

Abb. 26: Wiring diagram Condair RS - Double units (2 x "M") 40...80 kg/h

5.7.5 Wiring diagram RS - Linkup systems 100...160 kg/h

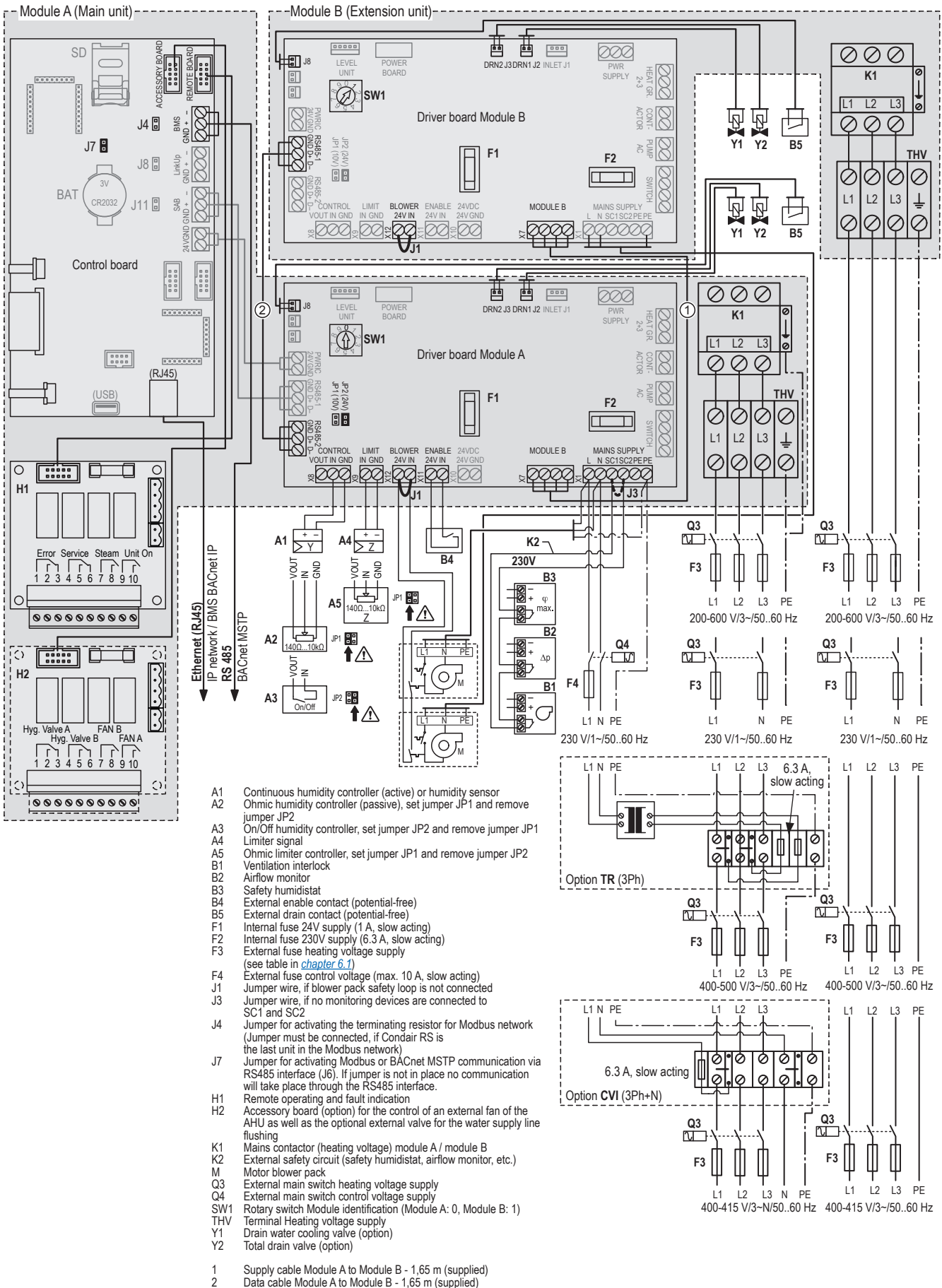

Abb. 27: Wiring diagram RS - Linkup systems 100...160 kg/h

Legend

A1	Continuous humidity controller (active) or humidity sensor
A2	Ohmic humidity controller (passive), set jumper JP1 and remove jumper JP2
A3	On/Off humidity controller, set jumper JP2 and remove jumper JP1
A4	Limiter signal
A5	Ohmic limiter controller, set jumper JP1 and remove jumper JP2
B1	Ventilation interlock
B2	Airflow monitor
B3	Safety humidistat
B4	External enable contact (potential-free)
B5	External drain contact (potential-free)
F1	Internal fuse 24V supply (1 A, slow acting)
F2	Internal fuse 230V supply (6.3 A, slow acting)
F3	External fuse heating voltage supply (see table in chapter 6.1)
F4	External fuse control voltage (max. 10 A, slow acting)
J1	Jumper wire, if blower pack safety loop is not connected
J3	Jumper wire, if no monitoring devices are connected to SC1 and SC2
J4	Jumper for activating the terminating resistor for Modbus network (Jumper must be connected, if Condair RS is the last unit in the Modbus network)
J7	Jumper for activating Modbus or BACnet MSTP communication via RS485 interface (J6). If jumper is not in place no communication will take place through the RS485 interface.
J8	Termination Linkup system (Jumper must be connected, if the Condair RS is the first or the last unit in the Linkup system).
H1	Remote operating and fault indication
H2	Accessory board (option) for the control of an external fan of the AHU as well as the optional external valve for the water supply line flushing
K1	Mains contactor (heating voltage) Main A / Main B and Extension A / Extension B
K2	External safety circuit (safety humidistat, airflow monitor, etc.)
M	Motor blower pack
Q3	External main switch heating voltage supply
Q4	External main switch control voltage supply
SW1	Rotary switch Module identification (Module A: 0, Module B: 1)
THV	Terminal Heating voltage supply
Y1	Drain water cooling valve (option)
Y2	Total drain valve (option)
1	Supply cable Module A to Module B - 1,65 m (supplied)
2	Data cable Module A to Module B - 1,65 m (supplied)
3	Linkup cable - 2,5 m (supplied)

5.7.6 Installation work external connections

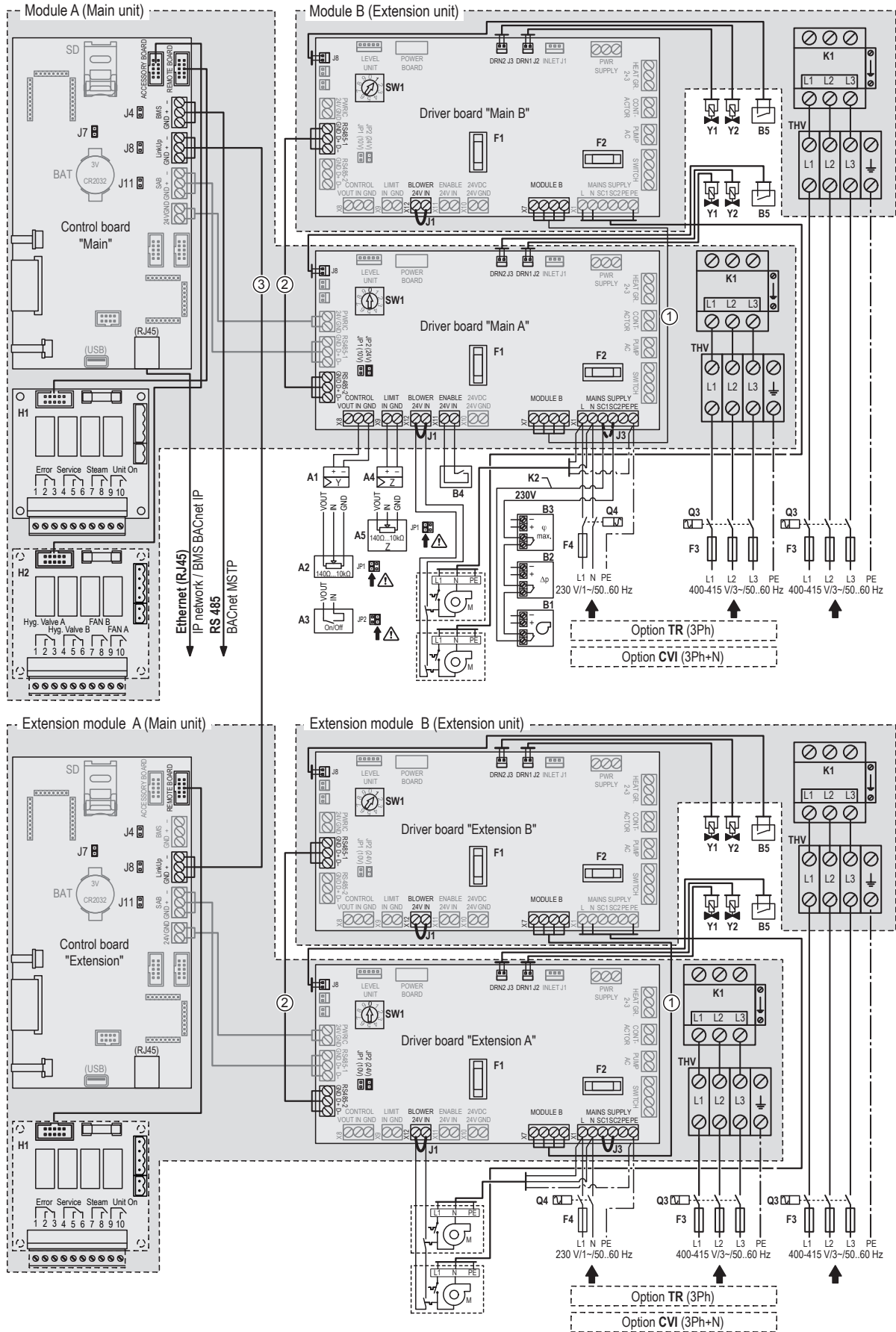
Connecting the external safety chain

DANGER:
230 V

Do not apply external voltage via K2!

Separate two-wire cables must be used to connect the potential-free contacts and the power supply of the monitoring devices!

The potential-free contacts of external monitoring devices (e.g. ventilation interlock "B1", airflow monitor "B2", safety high limit humidistat "B3", etc.) are connected in series (safety chain "K2") to the terminals "SC1" and "SC2" of the terminal block "X1" on the driver board with a two-wire cable in accordance with the wiring diagram. Note: The voltage supply of the external monitoring devices is established with separate two-wire cables connected to terminals "VOUT" and "GND" of the terminal block "X8" or via an external 24V AC/DC voltage supply.

Detailed information on connecting the monitoring devices can be found in the separate instructions for these devices.

The connecting cables must be led through cable glands into the control compartment.

Caution! A high limit humidistat is highly recommended to prevent risk of over-humidification and potential damage to property.

Note: If, for whatever reason, no external monitoring devices are connected, a jumper wire "J3" must be installed on the contacts "SC1" and "SC2" of the terminal block.

CAUTION! Do not apply any external voltage to contacts "SC1" and "SC2" via the contacts of the external monitoring devices.

Humidity control wiring

Connecting a demand or humidity signal

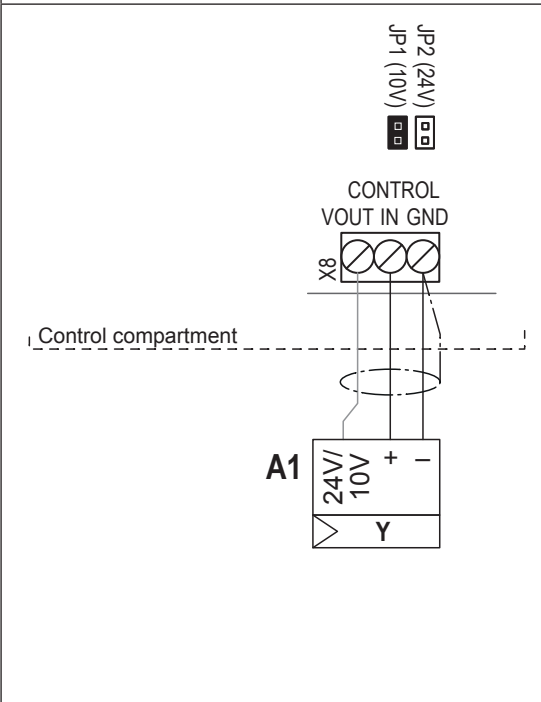

The signal cable of an external controller or of a humidity sensor (if the internal P/PI controller is used) are to be connected according to the wiring diagram to the terminals "IN" and "GND" on the driver board in the control compartment. The connecting cable must be led through a cable gland into the control compartment.

Note: if the external controller or the humidity sensor shall be supplied with 10 V or 24 V from the driver board (terminal "VOUT"), the jumper JP1 must be set to 10V or 24V accordingly.

Note: the humidity control must be configured via the control software accordingly. The admissible humidity control signal values can be found in the technical data table in the operation manual.

If a shielded signal cable is used, connect the shielding to terminal "GND".

Caution! If the shielding of the control signal is **already connected to a potential or a grounded conductor, do not** connect it to terminal "GND"

Connecting an ohmic humidity controller (passive)

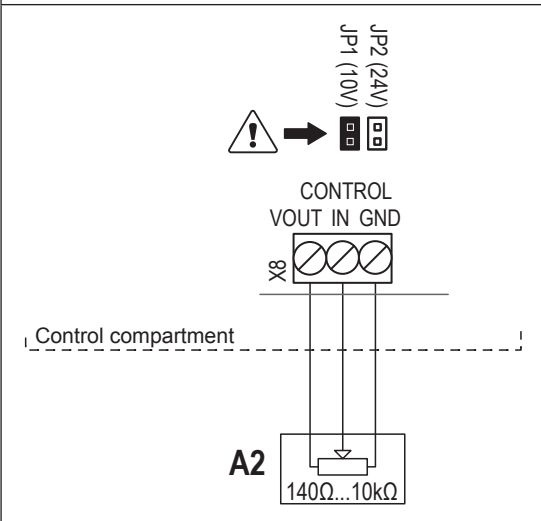

The signal cable of an ohmic humidity controller (140Ω...10kΩ) is to be connected according to the wiring diagram to the terminals "VOUT", "IN" and "GND" on the driver board in the control compartment. The connecting cable must be led through a cable gland into the control compartment.

The connecting cable must be led through a cable gland into the control compartment.

Note: when connecting an ohmic humidity controller Jumper "JP2" must be removed and Jumper "JP1" must be connected on the driver board and the control signal type must be set to 0-10V in the control settings of the control software.

Connecting a 24V On/Off humidistat

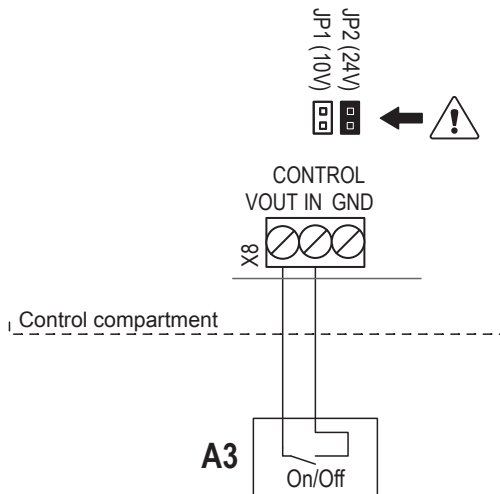

The signal cable of 24V On/Off humidistat is to be connected according to the wiring diagram to the terminals "VOUT" and "IN" on the driver board in the control compartment.

The connecting cable must be led through a cable gland into the control compartment.

Note: when connecting a 24V On/Off humidistat Jumper "JP1" must be removed and Jumper "JP2" connected.

Dimmer wiring

Connecting an external limiter controller or a humidity sensor

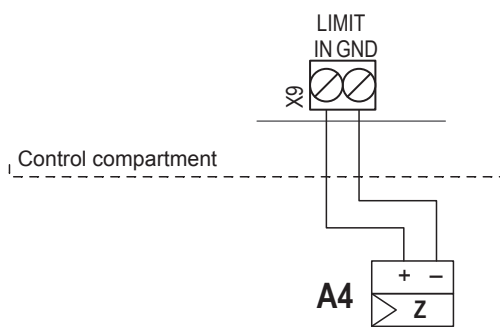

The signal cable of an external limiter (P/PI continuous controller) or of a humidity sensor (if the internal P/PI limiter controller is used) is to be connected according to the wiring diagram to the terminals "IN" (+) and "GND" (-) on the driver board in the control compartment.

The connecting cable must be led through a cable gland into the control compartment.

Note: the limiter must be activated and configured via the control software accordingly. The admissible limiter signal values can be found in the technical data table in the operation manual.

Connecting an external ohmic limiter controller

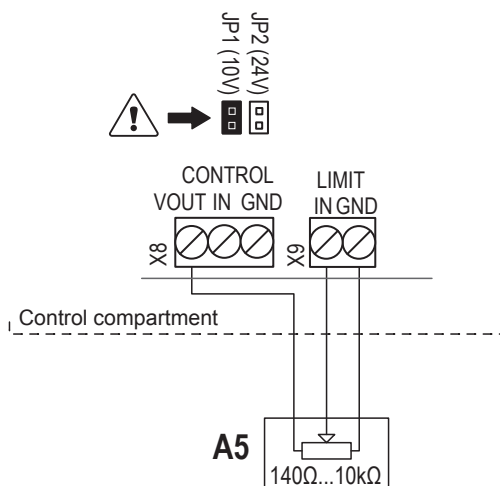

The signal cable of an ohmic limiter controller (140Ω...10kΩ) is to be connected according to the wiring diagram to the terminals "VOUT" (CONTROL terminal) and "IN" and "GND" (LIMIT terminal) on the driver board in the control compartment.

The connecting cable must be led through a cable gland into the control compartment.

Note: when connecting an ohmic limiter controller Jumper "JP2" must be removed and Jumper "JP1" must be connected on the driver board. The limiter must be activated and limiter signal type must be set to 0-10V in the control settings of the control software.

Connecting the remote operating and fault indication

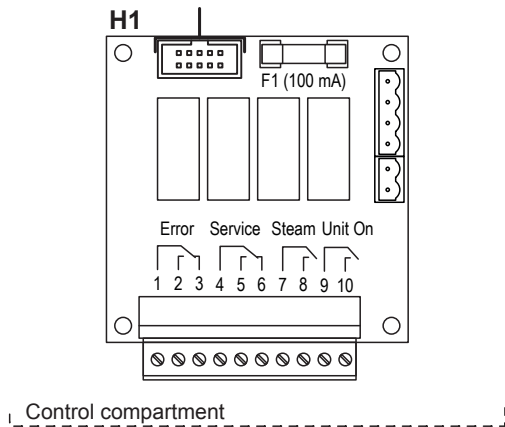

The remote operating and fault indication board contains four potential-free relay contacts for the connection of the following operating and fault indications:

- "Error" (Terminal 1 and 2):
This relay is activated if an error is present.
- "Service" (Terminal 4 and 5):
This relay is activated when the set maintenance interval has elapsed.
Note: this relay can be configured in the control software to close either when maintenance is required or when maintenance is required and when a warning is indicated.
- "Steam" (Terminal 7 and 8):
This relay closes as soon as the Condair EL humidifies.
- "Unit on" (Terminal 9 and 10):
This relay closes as soon as the voltage supply to the Control compartment of the Condair EL is switched on.

The connecting cable must be led through a cable gland or grommet into the control compartment.

The **maximum contact loading** is **250V/8A**.

Appropriate suppressor modules are to be used for the switching of relays and miniature contactors.

Connecting the optional accessory board

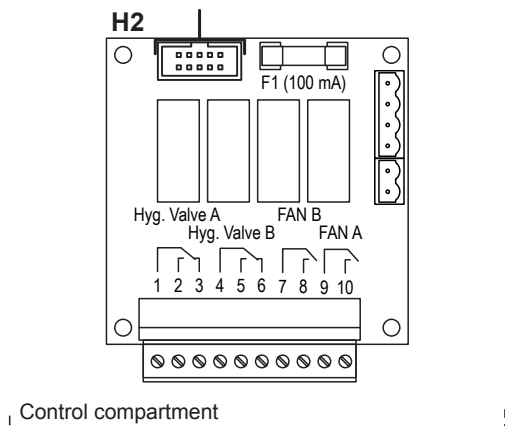

The optional accessory board contains four potential-free relay contacts to activate external fans of the AHU and the optional valves for flushing the water supply lines:

- "Hyg. Valve A" (Terminal 1 and 2):
This relay activates the optional valve for flushing the water supply line connected to module A.
- "Hyg. Valve B" (Terminal 4 and 5):
This relay activates the optional valve for flushing the water supply line connected to module B.
- "FAN B" (Terminal 7 and 8):
This relay activates an external fan of the AHU if module B is producing steam.
- "FAN A" (Terminal 9 and 10):
This relay activates an external fan of the AHU if module A is producing steam.

The connecting cable must be led through a cable gland or grommet into the control compartment.

The **maximum contact loading** is **250V/8A**.

Connecting the drain water cooling valve (option)

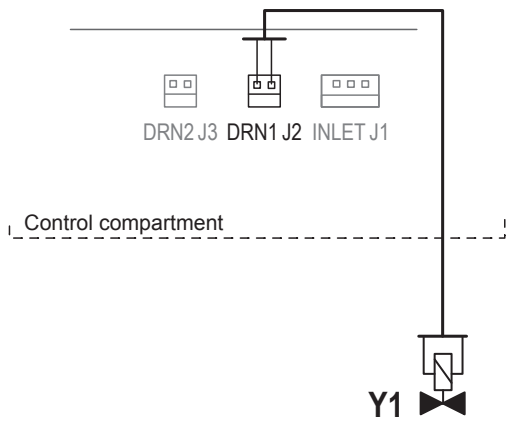

The connecting cable of the optional drain water cooling valve "Y1" is to be connected according to the wiring diagram to the terminal block "DRN1 J2" on the appropriate driver board in the control compartment.

The connecting cable must be led through a cable gland into the control compartment.

Note: if the optional drain water cooling valve is retrofitted, it must be activated via the control software. In this case contact your Condair representative.

Connecting the total drain valve (option)

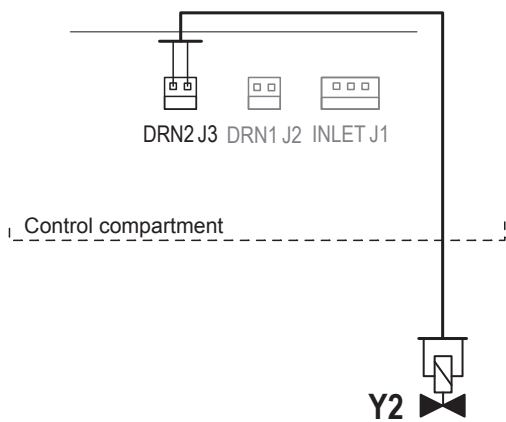

The connecting cable of the optional total drain valve "Y2" is to be connected according to the wiring diagram to the terminal block "DRN2 J3" on the appropriate driver board in the control compartment.

The connecting cable must be led through a cable gland into the control compartment.

Note: if the total drain valve is retrofitted, it must be activated via the control software. In this case contact your Condair representative.

Connecting the external drain contact (option)

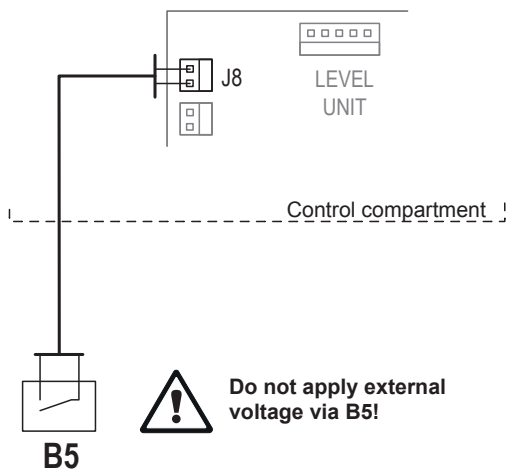

The potential-free contact of the external drain contact is connected to the terminals of the terminal block "J8" on the appropriate driver board in accordance with the wiring diagram.

The connecting cable must be led through a cable gland into the control compartment.

CAUTION! Do not apply any external voltage via the external drain contact "B5" to the terminals of terminal block "J8".

Connecting the control voltage

Note: if the Condair RS is equipped with option "CVI" or "TR", a separate control voltage supply is not required.

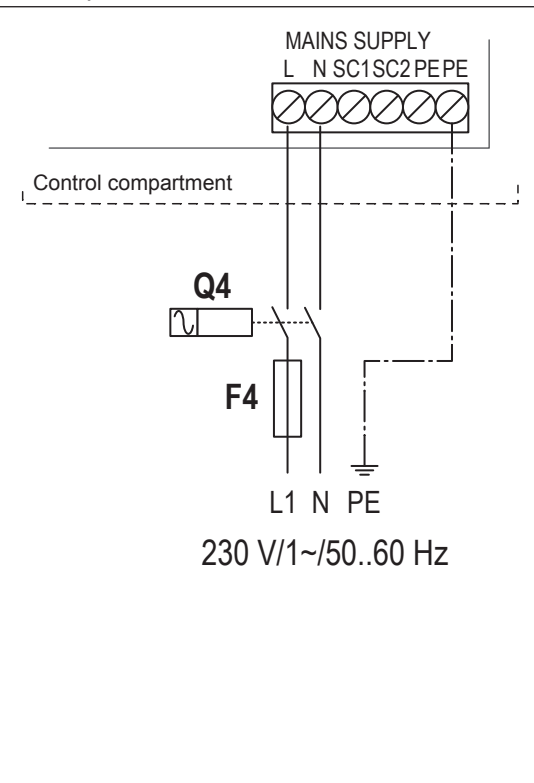

The control voltage supply (L1, N, PE) is to be connected in accordance with the wiring diagram to the corresponding terminals on the driver board in the control compartment.

The installation of the **fuse "F4"** (10A, slow acting) and the **electrical isolator "Q4"** (all pole disconnecting device with a minimum contact clearance of 3 mm, supplied by others) in the mains supply line are mandatory. For safety reasons the additional installation of a residual current circuit breaker in the mains supply line (supplied by others) is recommended. However, the local electrical installation regulations must be observed and adhered to.

The electrical isolator must be mounted in direct proximity of the control compartment (max. distance 1 m) and must be easily accessible in a height between 0.6 m and 1.9 m (recommended: 1.7 m).

CAUTION! Make sure the voltage indicated on the specification label meets the local mains voltage. Otherwise, do not connect the unit.

The cross-section of the cable must comply with the applicable local regulations (minimum of 1.5 mm²).

Connecting the heating voltage supply

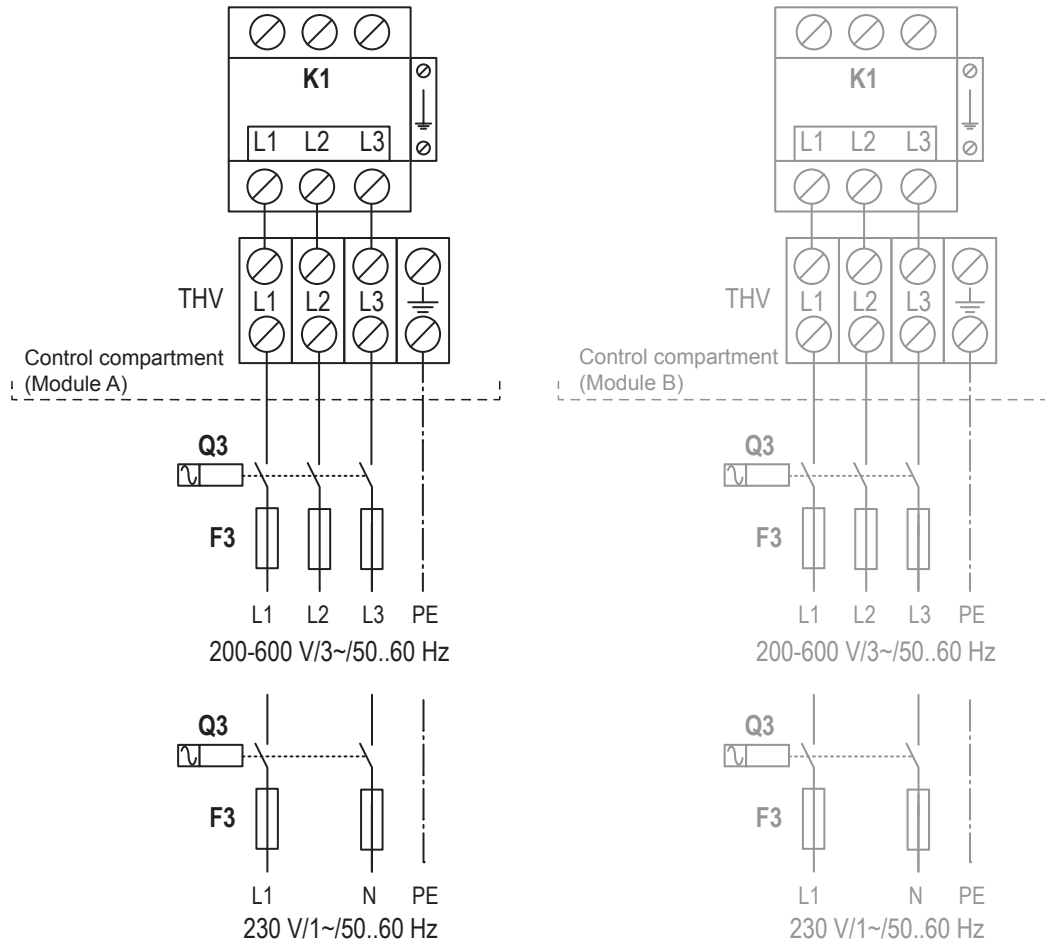

The **heating voltage supply** (L1, L2, L3 and PE or L1, N and PE) is to be connected in accordance with the wiring diagram to the corresponding terminals of the terminal strip "THV" in the control compartment. The supply wiring is to be fed into the unit via the cable guide with clamp on the bottom of the unit.

Notes:

- Double units consisting of two housings have separate heating voltage supplies for each module (cylinder).
- Large units with two cylinders have a single heating voltage supply which is connected to the terminals of terminal strip "X0" and from there branched to each of the two modules (see wiring diagram in [chapter 5.7.3](#)).

The installation of the **fuses "F3"** and the **electrical isolator "Q3"** (all pole disconnecting device with a minimum contact clearance of 3 mm, supplied by others) in the mains supply line are mandatory.

Note: a table with the values for the fuses "F3" is to be found in [chapter 6.1](#).

For safety reasons the additional installation of a residual current circuit breaker in the mains supply line (supplied by others) is recommended. However, the local electrical installation regulations must be observed and adhered to.

The electrical isolator must be mounted in direct proximity of the control compartment (max. distance 1 m) and must be easily accessible in a height between 0.6 m and 1.9 m (recommended: 1.7 m).

CAUTION! Make sure the voltage indicated on the specification label meets the local mains voltage. Otherwise, do not connect the unit.

The cross-section of the mains cable must comply with the applicable local regulations.

Connecting the voltage supply via option TR (for 3 phase single voltage system)

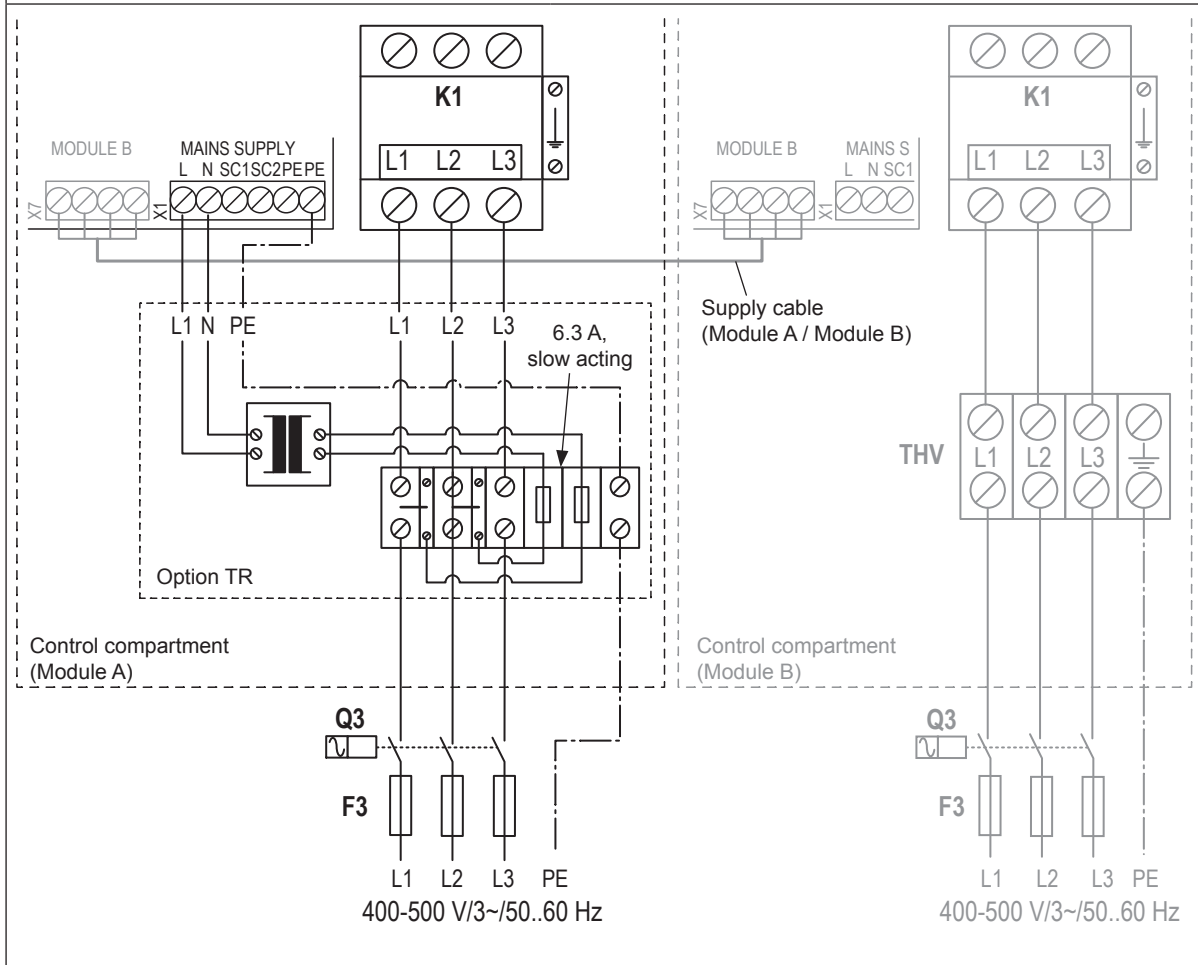

The **voltage supply** (L1, L2, L3 and PE) is to be connected in accordance with the wiring diagram of the option TR. The supply wiring is to be fed into the unit via the clamp strap on the bottom of the unit.

Note: On double units consisting of two housings the heating voltage supply for module B is connected to the corresponding terminals of the terminal strip "THV". The control voltage supply to module B is established via the supply cable connected to the terminal strips "X7" on the driver boards of module A and module B.

The installation of the **fuses "F3"** and the **electrical isolator "Q3"** (all pole disconnecting device with a minimum contact clearance of 3 mm, supplied by others) in the mains supply line are mandatory.

Note: a table with the values for the fuses "F3" is to be found in [chapter 6.1](#).

For safety reasons the additional installation of a residual current circuit breaker in the mains supply line (supplied by others) is recommended. However, the local electrical installation regulations must be observed and adhered to.

The electrical isolator must be mounted in direct proximity of the control compartment (max. distance 1 m) and must be easily accessible in a height between 0.6 m and 1.9 m (recommended: 1.7 m).

CAUTION! Make sure the voltage indicated on the specification label meets the local mains voltage. Otherwise, do not connect the unit.

The cross-section of the mains cable must comply with the applicable local regulations.

Connecting the voltage supply via Option CVI (for 3 phase/neutral single voltage system)

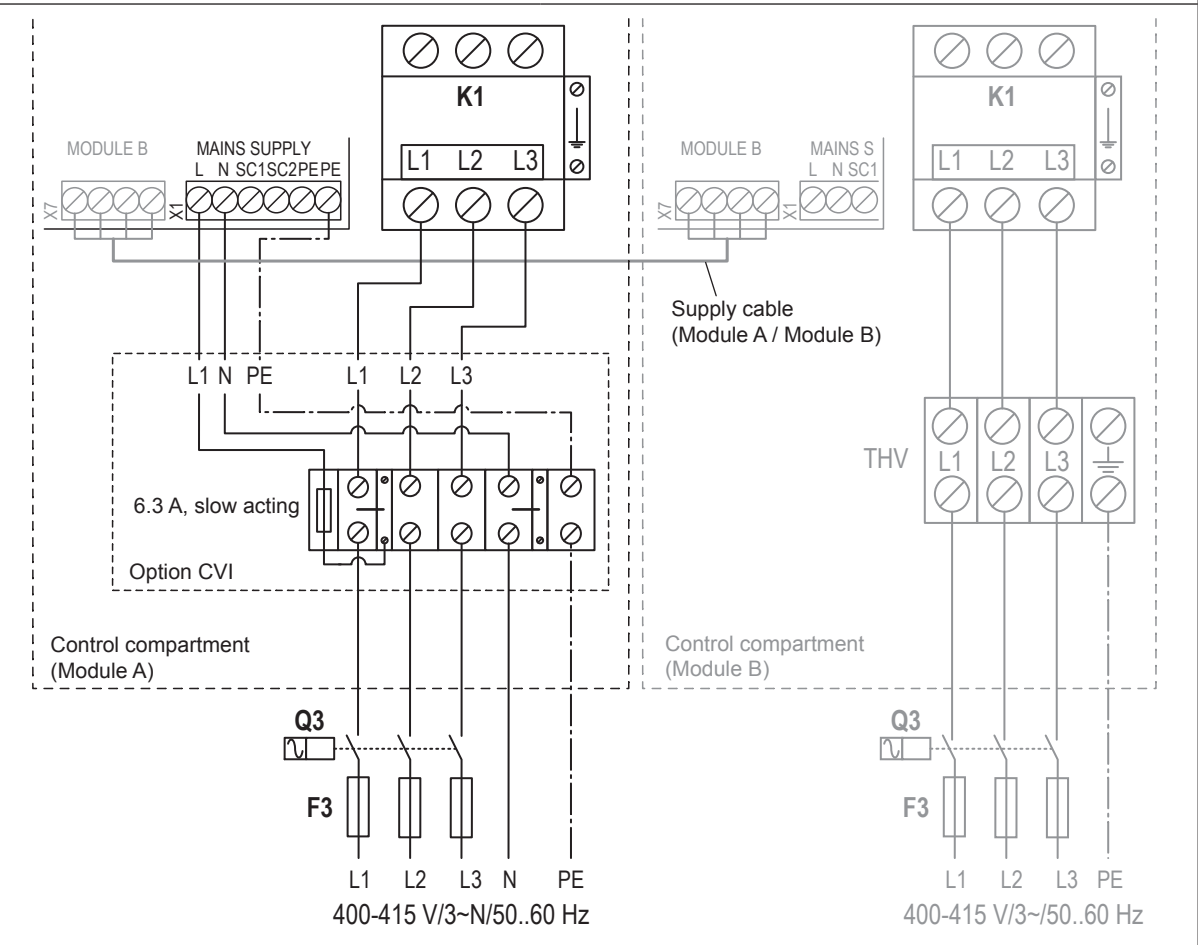

The **voltage supply** (L1, L2, L3, N and PE) is to be connected in accordance with the wiring diagram to the corresponding terminals of the option CVI. The supply wiring is to be fed into the unit via the clamp strap on the bottom of the unit.

Note: On double units consisting of two housings the heating voltage supply for module B is connected to the corresponding terminals of the terminal strip "THV". The control voltage supply to module B is established via the supply cable connected to the terminal strips "X7" on the driver boards of module A and module B.

The installation of the **fuses "F3"** and the **electrical isolator "Q3"** (all pole disconnecting device with a minimum contact clearance of 3 mm, supplied by others) in the mains supply line are mandatory.

Note: a table with the values for the fuses "F3" is to be found in [chapter 6.1](#).

For safety reasons the additional installation of a residual current circuit breaker in the mains supply line (supplied by others) is recommended. However, the local electrical installation regulations must be observed and adhered to.

The electrical isolator must be mounted in direct proximity of the control compartment (max. distance 1 m) and must be easily accessible in a height between 0.6 m and 1.9 m (recommended: 1.7 m).

CAUTION! Make sure the voltage indicated on the specification label meets the local mains voltage. Otherwise, do not connect the unit.

The cross-section of the mains cable must comply with the applicable local regulations.

Connecting the blower pack BP

See separate documentation for blower pack BP.

5.7.7 Inspecting the electrical installation

Check the following points:

- Do the supply voltages for heating and control voltage comply with the relevant voltages stated on the specification label?
- Are the voltage supplies (heating and control voltage) correctly fused?
- Are the service switches "Q.." installed in the supply lines for to the heating and control voltage?
- Are all components correctly connected according to the wiring diagram?
- Are all connecting cables fastened?
- Are the connecting cables free of tension (passed through cable glands?)
- Does the electric installation meet the applicable local regulations for electric installations?
- Is the unit reassembled correctly and the front panel fixed with the screw?

6 Product specifications

6.1 Performance data / Fuses "F3" Heating voltage supply

		230V/1-~50...60 Hz					200V/3-~50...60 Hz					230V/3-~50...60 Hz					380V/3-~50...60 Hz					400V/3-~50...60 Hz					415V/3-~50...60 Hz									
		Max. steam capacity in kg/h	P ₁ max. in kW	I ₁ max. in A	Cable cross section A ₁ min. in mm ²	Fuses "F3" in A, quick acting (gR)	Max. steam capacity in kg/h	P ₁ max. in kW	I ₁ max. in A	Cable cross section A ₁ min. in mm ²	Fuses "F3" in A, quick acting (gR)	Max. steam capacity in kg/h	P ₁ max. in kW	I ₁ max. in A	Cable cross section A ₁ min. in mm ²	Fuses "F3" in A, quick acting (gR)	Max. steam capacity in kg/h	P ₁ max. in kW	I ₁ max. in A	Cable cross section A ₁ min. in mm ²	Fuses "F3" in A, quick acting (gR)	Max. steam capacity in kg/h	P ₁ max. in kW	I ₁ max. in A	Cable cross section A ₁ min. in mm ²	Fuses "F3" in A, quick acting (gR)	Max. steam capacity in kg/h	P ₁ max. in kW	I ₁ max. in A	Cable cross section A ₁ min. in mm ²	Fuses "F3" in A, quick acting (gR)					
S	RS 5	5.0	3.8	16.4	4.0	20	—	—	—	—	—	—	—	—	—	—	5.0	3.8	9.4	1.5	16	4.6	3.4	5.2	1.5	10	5.0	3.8	5.5	1.5	10	5.4	4.1	5.7	1.5	10
	RS 8	8.0	6.0	26.0	6.0	32	—	—	—	—	—	8.0	6.0	15.0	2.5	20	7.3	5.4	8.3	1.5	10	8.0	6.0	8.7	1.5	10	8.7	6.5	9.0	1.5	10					
	RS 10	9.8	7.4	32.1	10.0	40	—	—	—	—	—	9.8	7.4	18.5	6.0	32	9.0	6.7	10.2	1.5	16	10.0	7.4	10.7	1.5	16	10.7	8.0	11.1	1.5	16					
M	RS 16	—	—	—	—	—	14.9	11.2	32.2	10.0	40	16.0	12.0	30.1	10.0	40	14.5	10.9	16.6	2.5	20	16.0	12.1	17.4	2.5	20	17.3	13.0	18.1	2.5	20					
	RS 20	—	—	—	—	—	18.1	13.6	39.2	16.0	63	19.7	14.8	37.1	16.0	63	17.9	13.4	20.4	6.0	25	20.0	14.9	21.5	6.0	25	21.4	16.0	22.3	4.0	25					
	RS 24	—	—	—	—	—	22.3	16.7	48.3	16.0	63	24.0	18.0	45.1	16.0	63	21.8	16.3	24.8	6.0	32	24.0	18.2	26.1	6.0	32	26.0	19.5	27.1	6.0	32					
	RS 30	—	—	—	—	—	30.0	22.5	65.0	25.0	80	29.5	22.1	55.6	25.0	80	26.9	20.1	30.6	10.0	40	30.0	22.3	32.2	10.0	40	32.0	24.0	33.4	10.0	40					
	RS 40	—	—	—	—	—	—	—	—	—	—	—	—	—	—	—	36.1	27.1	41.1	16.0	63	40.0	30.0	43.3	16.0	63	43.1	32.3	44.9	16.0	63					
	2*M	RS 40	—	—	—	—	—	2*18.1	2*13.6	2*39.2	2*16.0	2*63	2*19.7	2*14.8	2*37.1	2*16.0	2*63	—	—	—	—	—	—	—	—	—	—	—	—	—	—	—	—	—		
2*M/L ¹⁾	RS 50 + B	—	—	—	—	—	18.1 + 30.0	13.6 + 22.5	39.2 + 65.0	16.0 + 25.0	63 + 80	19.7 + 29.5	14.8 + 22.1	37.1 + 55.6	16.0 + 25.0	63 + 80	17.9 + 26.9	13.4 + 20.1	20.4 + 30.6	6.0 + 10.0	25 + 40	20.0 + 30.0	14.9 + 22.3	21.5 + 32.2	6.0 + 10.0	25 + 40	21.4 + 24.0	16.0 + 33.4	22.3 + 34.0	4.0 + 10.0	25 + 40					
	L	RS 50	—	—	—	—	—	—	—	—	—	—	—	—	—	—	—	—	—	—	—	—	—	—	—	—	—	—	—	—	—	—	—			
2*M/L ¹⁾	RS 60	—	—	—	—	—	2*30.0	2*22.5	2*65.0	2*25.0	2*80	2*29.5	2*22.1	2*55.6	2*25.0	2*80	2*26.9	2*20.1	2*30.6	2*10.0	2*40	2*30.0	2*22.3	2*32.2	2*10.0	2*40	2*32.0	2*24.0	2*33.4	2*10.0	2*40					
	L	RS 60	—	—	—	—	—	—	—	—	—	—	—	—	—	—	—	—	—	—	—	—	—	—	—	—	—	—	—	—	—	—	—			
2*M/L ¹⁾	RS 80	—	—	—	—	—	—	—	—	—	—	—	—	—	—	—	2*36.1	2*27.1	2*41.1	2*16.0	2*63	2*40.0	2*30.0	2*43.3	2*16.0	2*63	2*43.1	2*32.3	2*44.9	2*16.0	2*63					
	L	RS 80	—	—	—	—	—	—	—	—	—	—	—	—	—	—	—	—	—	—	—	—	—	—	—	—	—	—	—	—	—	—	—			
3*M	RS 100 + E	—	—	—	—	—	—	—	—	—	—	—	—	—	—	—	—	—	—	—	—	—	—	—	—	—	—	—	—	—	—	—	—			
	RS 120	—	—	—	—	—	—	—	—	—	—	—	—	—	—	—	—	—	—	—	—	—	—	—	—	—	—	—	—	—	—	—	—			
4*M	RS 140 + E	—	—	—	—	—	—	—	—	—	—	—	—	—	—	—	—	—	—	—	—	—	—	—	—	—	—	—	—	—	—	—	—			
	RS 160	—	—	—	—	—	—	—	—	—	—	—	—	—	—	—	—	—	—	—	—	—	—	—	—	—	—	—	—	—	—	—	—			

¹⁾ Only for "L" units if they are connected with two separate heating voltage supply lines.

		440V/3-~50...60 Hz					460V/3-~50...60 Hz					480V/3-~50...60 Hz					500V/3-~50...60 Hz					600V/3-~50...60 Hz										
		Max. steam capacity in kg/h	P ₁ max. in kW	I ₁ max. in A	Cable cross section A ₁ min. in mm ²	Fuses "F3" in A, quick acting (gR)	Max. steam capacity in kg/h	P ₁ max. in kW	I ₁ max. in A	Cable cross section A ₁ min. in mm ²	Fuses "F3" in A, quick acting (gR)	Max. steam capacity in kg/h	P ₁ max. in kW	I ₁ max. in A	Cable cross section A ₁ min. in mm ²	Fuses "F3" in A, quick acting (gR)	Max. steam capacity in kg/h	P ₁ max. in kW	I ₁ max. in A	Cable cross section A ₁ min. in mm ²	Fuses "F3" in A, quick acting (gR)	Max. steam capacity in kg/h	P ₁ max. in kW	I ₁ max. in A	Cable cross section A ₁ min. in mm ²	Fuses "F3" in A, quick acting (gR)	Max. steam capacity in kg/h	P ₁ max. in kW	I ₁ max. in A	Cable cross section A ₁ min. in mm ²	Fuses "F3" in A, quick acting (gR)	
S	RS 5	—	—	—	—	—	—	—	—	—	—	—	—	—	—	—	—	—	—	—	—	—	—	—	—	—	—	—	—	—	—	—
	RS 8	—	—	—	—	—	—	—	—	—	—	—	—	—	—	—	—	—	—	—	—	—	—	—	—	—	—	—	—	—	—	—
	RS 10	10.8	8.1	10.6	1.5	16	11.8	8.8	11.1	1.5	16	12.8	9.6	11.5	1.5	16	13.9	10.4	12.0	1.5	16	10.3	7.7	7.4	1.5	16						
M	RS 16	15.3	11.5	15.1	2.5	20	16.7	12.6	15.8	2.5	20	18.2	13.7	16.4	2.5	20	19.8	14.8	17.1	2.5	20	14.2	10.7	10.3	1.5	16						
	RS 20	17.2	12.9	16.9	2.5	20	18.8	14.1	17.7	4.0	25	20.5	15.4	18.5	4.0	25	22.2	16.7	19.2	4.0	25	21.3	16.0	15.4	2.5	20						
	RS 24	—	—	—	—	—	—	—	—	—	—	—	—	—	—	—	—	—	—	—	—	—	—	—	—	—	—	—	—	—	—	—
	RS 30	24.0	18.0	23.6	6.0	32	26.2	19.7	24.7	6.0	32	28.6	21.4	25.8	6.0	32	31.0	23.3	26.9	6.0	32	32.0	24.0	23.1	6.0	32						
	RS 40	36.0	27.0	35.4	16.0	63	39.4	29.5	37.1	16.0	63	42.9	32.1	38.7	16.0	63	46.5	34.9	40.3	16.0	63	42.7	32.0	30.8	10.0	40						
	2*M	RS 40	—	—	—	—	—	—	—	—	—	—	—	—	—	—	—	—	—	—	—	—	—	—	—	—	—	—	—	—	—	—
L	RS 50 + B	17.2 + 24.0	12.9 + 18.0	16.9 + 23.6	2.5 + 6.0	20 32	18.8 + 26.2	14.1 + 19.7	17.7 + 24.7	4.0 + 6.0	25 32	20.5 + 28.6	15.4 + 21.4	18.5 + 25.8	4.0 + 6.0	25 32	22.2 + 31.0	16.7 + 23.3	19.2 + 26.9	4.0 + 6.0	25 32	21.3 + 32.0	16.0 + 24.0	15.4 + 23.1	2.5 + 6.0	20 32						
	L	RS 50	—	—	—	—	—	—	—	—	—	—	—	—	—	—	—	—	—	—	—	—	—	—	—	—	—	—	—	—	—	—
2*M	RS 60	2*24.0	2*18.0	2*23.6	2*6.0	2*32	2*26.2	2*19.7	2*24.7	2*6.0	2*32	2*28.6	2*21.4	2*25.8	2*6.0	2*32	2*31.0	2*23.3	2*26.9	2*6.0	2*32	2*32.0	2*24.0	2*23.1	2*6.0	2*32						
	L	RS 60	—	—	—	—	—	—	—	—	—	—	—	—	—	—	—	—	—	—	—	—	—	—	—	—	—	—	—	—	—	—
2*M	RS 80	2*36.0	2*27.0	2*35.4	2*16.0	2*63	2*39.4	2*29.5	2*37.1	2*16.0	2*63	2*42.9	2*32.1	2*38.7	2*16.0	2*63	2*46.5	2*34.9	2*40.3	2*16.0	2*63	2*42.7	2*32.0	2*30.8	2*10.0	2*40						
	L	RS 80	—	—	—	—	—	—	—	—	—	—	—	—	—	—	—	—	—	—	—	—	—	—	—	—	—	—	—	—	—	—
3*M	RS 100	—	—	—	—	—	—	—	—	—	—	—	—	—	—	—	—	—	—	—	—	—	—	—	—	—	—	—	—	—	—	—
	RS 120	—	—	—	—	—	—	—	—	—	—	—	—	—	—	—	—	—	—	—	—	—	—	—	—	—	—	—	—	—	—	—
4*M	RS 140	—	—	—	—	—	—	—	—	—	—	—	—	—	—	—	—	—	—	—	—	—	—	—	—	—	—	—	—	—	—	—
	RS 160	—	—	—	—	—	—	—	—	—	—	—	—	—	—	—	—	—	—	—	—	—	—	—	—	—	—	—	—	—	—	—

A= Module A, B= Module B, M= Main unit, E= Extension unit

6.2 Operating data

Achievable control accuracy	Note: The achievable control accuracy is influenced by the placement of the humidity sensor. Regarding the achievable control accuracy, please refer to chapter 5.6 (humidity control systems/humidity control) and chapter 5.4.2 (placement of the steam distributor).
– Standard unit	±5 % absolute humidity (with PI-control and use of untreated drinking water) ±2 % absolute humidity (with PI-control and use of de-ionized water)
– Option P unit	±2 % absolute humidity (with PI-control and use of untreated drinking water) ±1 % absolute humidity (with PI-control and use of de-ionized water)
	Note: During the drain cycle (operation with tap water) or during the refill cycle (operation with de-ionized water) the control accuracy can deviate from the above stated values.
	Note: When operating the Condair RS with option P with tap water the control accuracy can deviate from the above stated values during the drain cycle. For process air humidification with constant control accuracy the Condair RS with option P must be operated with de-ionized water and the drain cycle must be deactivated.
Control steam output	
– active	0...5 VDC, 1...5 VDC, 0...10 VDC, 2...10 VDC, 0...20 VDC, 0...16 VDC, 3.2...16 VDC, 0...20 mADC, 4...20 mADC
– passive	all potentiometric humidity sensors from 140 Ω...10 kΩ
– On/Off control	<2.5 VDC --> Off; ≥2.5 VDC...20 VDC --> On
Duct air pressure	Overpressure max. 1500 Pa, Underpressure max. 1000 Pa (for duct pressures outside these values contact your Condair representative)
Admissible ambient temperature	1...40 °C
Admissible ambient humidity	1...75 %rh (non-condensing)
Water supply	
– Admissible water supply pressure	1...10 bar (with optional drain water cooling 2...10 bar)
– Admissible Feed temperature	1...40 °C (with optional drain water cooling 1...25 °C)
– Water quality	Untreated drinking water, RO water, de-ionized water (for operation with softened or partly softened water please contact your Condair representative)
Water drain	
– Drain water temperature	60...90 °C
Protection class	IP21

6.3 Connections/Dimensions/Weights

Water supply connector	G 3/4"
Water drain connector	ø30 mm
Steam connector	ø45.0 mm
Housing dimensions	
– Small unit (S) - HxWxD	670 mm (987 mm *) x 420 mm x 370 mm
– Medium unit (M) - HxWxD	780 mm (1097 mm *) x 530 mm x 406 mm
– Large unit (L) - HxWxD	780 mm (1097 mm *) x 1000 mm x 406 mm
	* Height with scale collector tank
Unit weights	
– Small unit (S) - Net weight/operating weight	27.2 kg / 40.2 kg
– Medium unit (M) - Net weight/operating weight	40.3 kg / 65.8 kg
– Large unit (L) - Net weight/operating weight	81.0 kg / 132.0 kg

6.4 Certificates

Certificates	CE, VDE
--------------	---------

6.5 Standard settings for water reduction time and maintenance interval time dependent on the water quality

Steam capacity	Water reduction time			Maintenance interval time			
	Tap water *	RO water **	DI water ***	Small Maintenance		Extended Maintenance	
				Tap water *	RO water ** DI water ***	Tap water *	RO water ** DI water ***
5 kg/h	30 min	180 min	360 min	500 h	3000 h	1500 h	3000 h
8 kg/h	20 min	180 min	360 min	500 h	3000 h	1500 h	3000 h
10 kg/h	20 min	180 min	360 min	500 h	3000 h	1500 h	3000 h
16 kg/h	10 min	180 min	360 min	450 h	3000 h	1350 h	3000 h
20 kg/h	7 min	180 min	360 min	400 h	3000 h	1200 h	3000 h
24 kg/h	7 min	180 min	360 min	400 h	3000 h	1200 h	3000 h
30 kg/h	5 min	180 min	360 min	350 h	3000 h	1050 h	3000 h
40 kg/h	5 min	180 min	360 min	350 h	3000 h	1050 h	3000 h
50 kg/h	5 min	180 min	360 min	350 h	3000 h	1050 h	3000 h
60 kg/h	5 min	180 min	360 min	350 h	3000 h	1050 h	3000 h
80 kg/h	5 min	180 min	360 min	350 h	3000 h	1050 h	3000 h
100 kg/h	5 min	180 min	360 min	350 h	3000 h	1050 h	3000 h
120 kg/h	5 min	180 min	360 min	350 h	3000 h	1050 h	3000 h
140 kg/h	5 min	180 min	360 min	350 h	3000 h	1050 h	3000 h
160 kg/h	5 min	180 min	360 min	350 h	3000 h	1050 h	3000 h

* The standard settings for untreated tap water refer to a water hardness of 20 °dH or 36 °fH or 360 ppm, respectively)

** Standard settings for water from a reverse osmosis system (RO water) >5 ... ≤ 30 µS/cm

*** Standard settings for de-ionized water (DI water) ≤ 5 µS/cm

7 Appendix

7.1 Dimensional drawings

7.1.1 Dimensional drawing RS 5 - 10, size "S"



Abb. 28: Dimensional drawing unit "Small" (dimensions in mm)

7.1.2 Unit dimensions RS 16 - 40 and RS 40 - 80 (single housing), size "M"

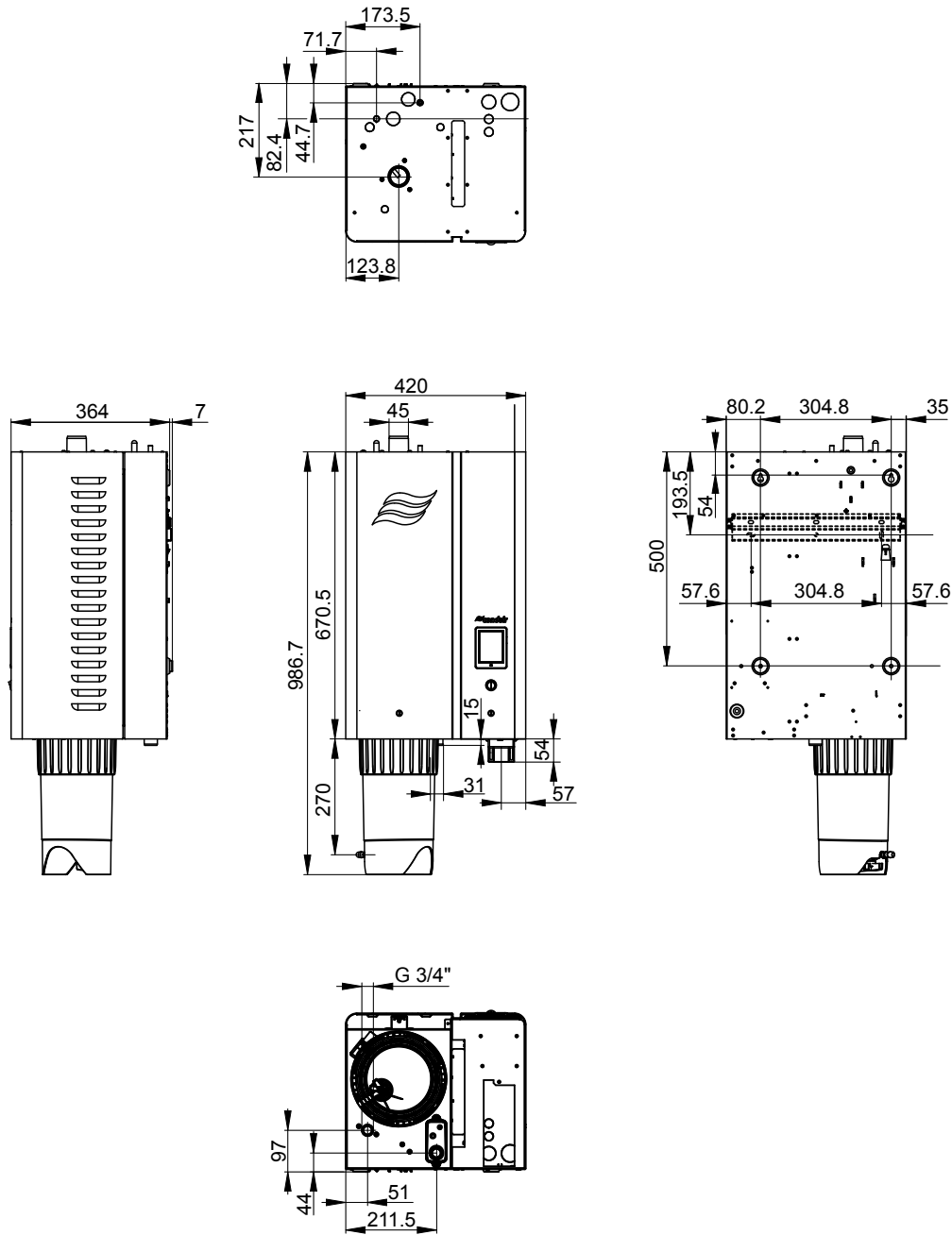

Abb. 29: Dimensional drawing unit "Medium" (dimensions in mm)

7.1.3 Unit dimensions RS 50 - 80 (double housing), size "L"

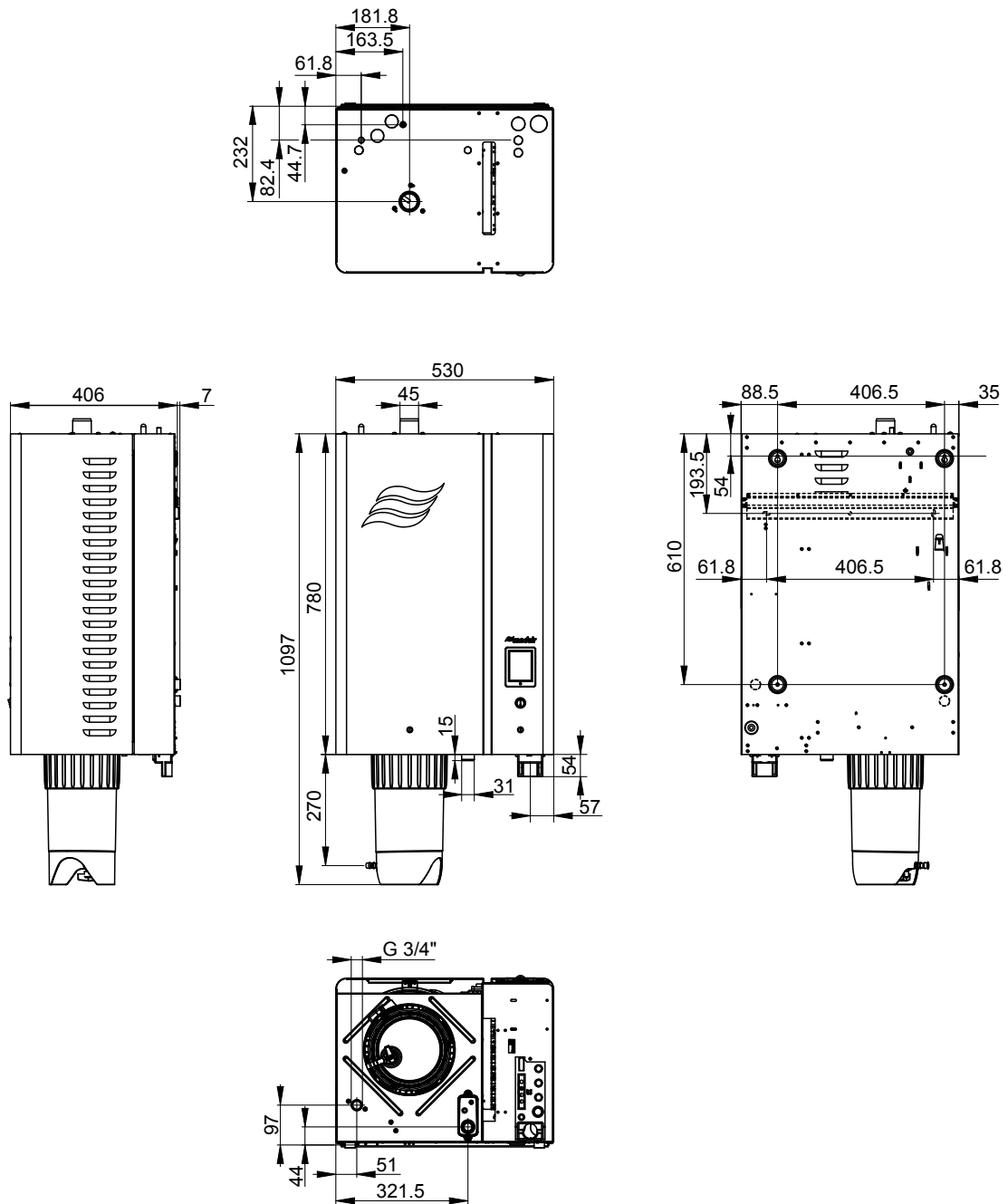

Abb. 30: Dimensional drawing unit "Large" (dimensions in mm)

7.2 EC Declaration of conformity

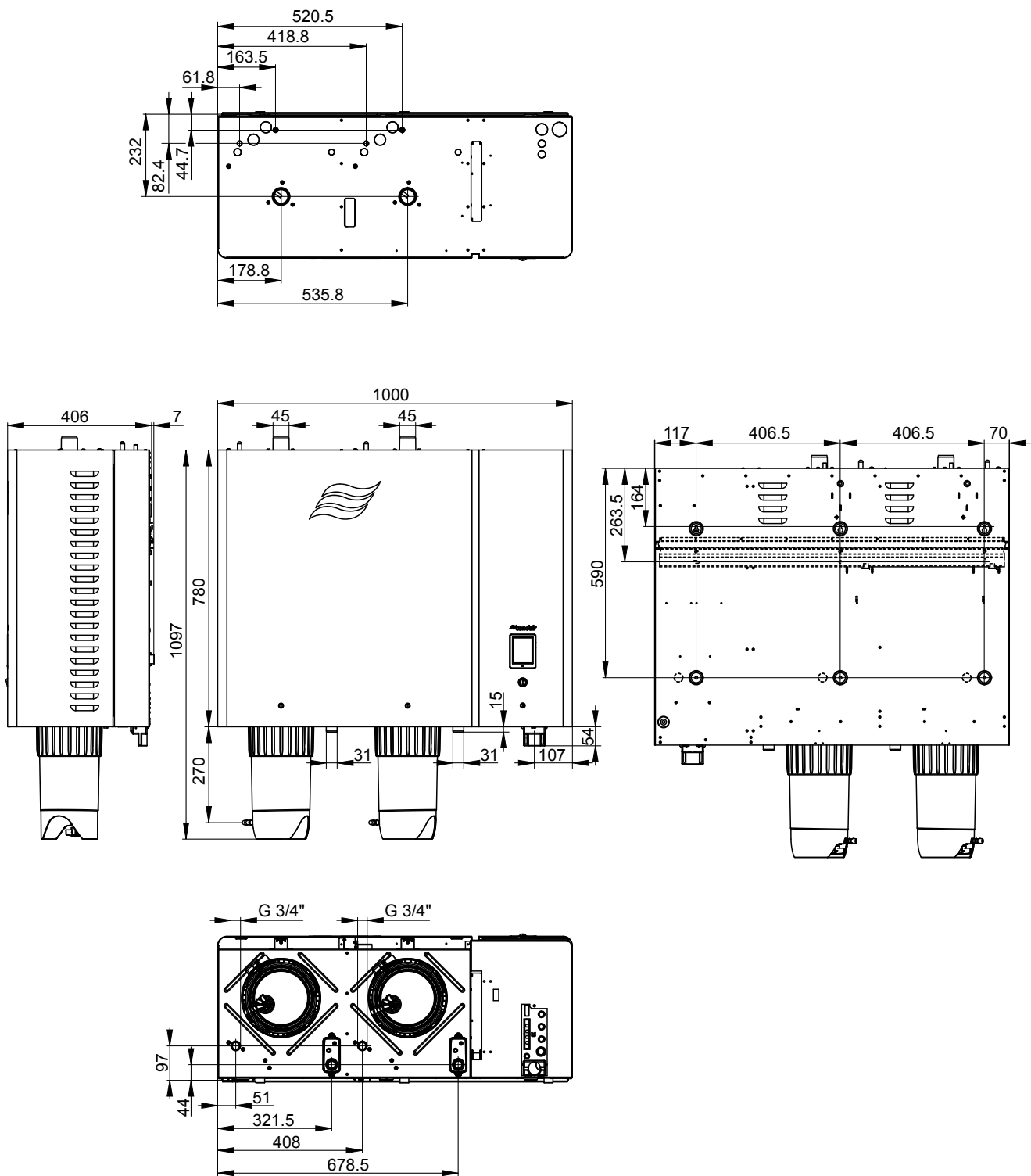

EC

Konformitätserklärung

Declaration of conformity

Déclaration de conformité

Wir,
Condair Group AG
CH-8808 Pfäffikon SZ
erklären in alleiniger Verantwortung,
dass das Produkt

We,
Condair Group AG
CH-8808 Pfäffikon SZ
declare under our sole responsibility, that
the product

Nous,
Condair Group AG
CH-8808 Pfäffikon SZ
déclarons sous notre seule
responsabilité, que le produit

Condair RS

auf das sich diese Erklärung bezieht,
mit den folgenden Normen oder
normativen Dokumenten
übereinstimmt

to which this declaration relates is in
conformity with the following standards or
other normative standards

auquel se réfère cette déclaration est
conforme aux normes ou autres
documents normatifs

EN 61000-6-2
EN 61000-6-3
EN 60335-1
EN 60335-2-98
EN 62233

und den Bestimmungen der folgenden
Richtlinien entspricht

and is corresponding to the following
provisions of directives

et est conforme aux dispositions des
directives suivantes

2014 / 35 / EU
2014 / 30 / EU

2581051 DE/EN/FR 1905

Pfäffikon, May 01, 2019

Condair Group AG

Robert Merki
Head of Engineering

Condair Group AG
Gwattstrasse 17
8808 Pfäffikon, Switzerland
Tel. +41 55 416 61 11, Fax +41 55 588 00 07
info@condair.com, www.condairgroup.com

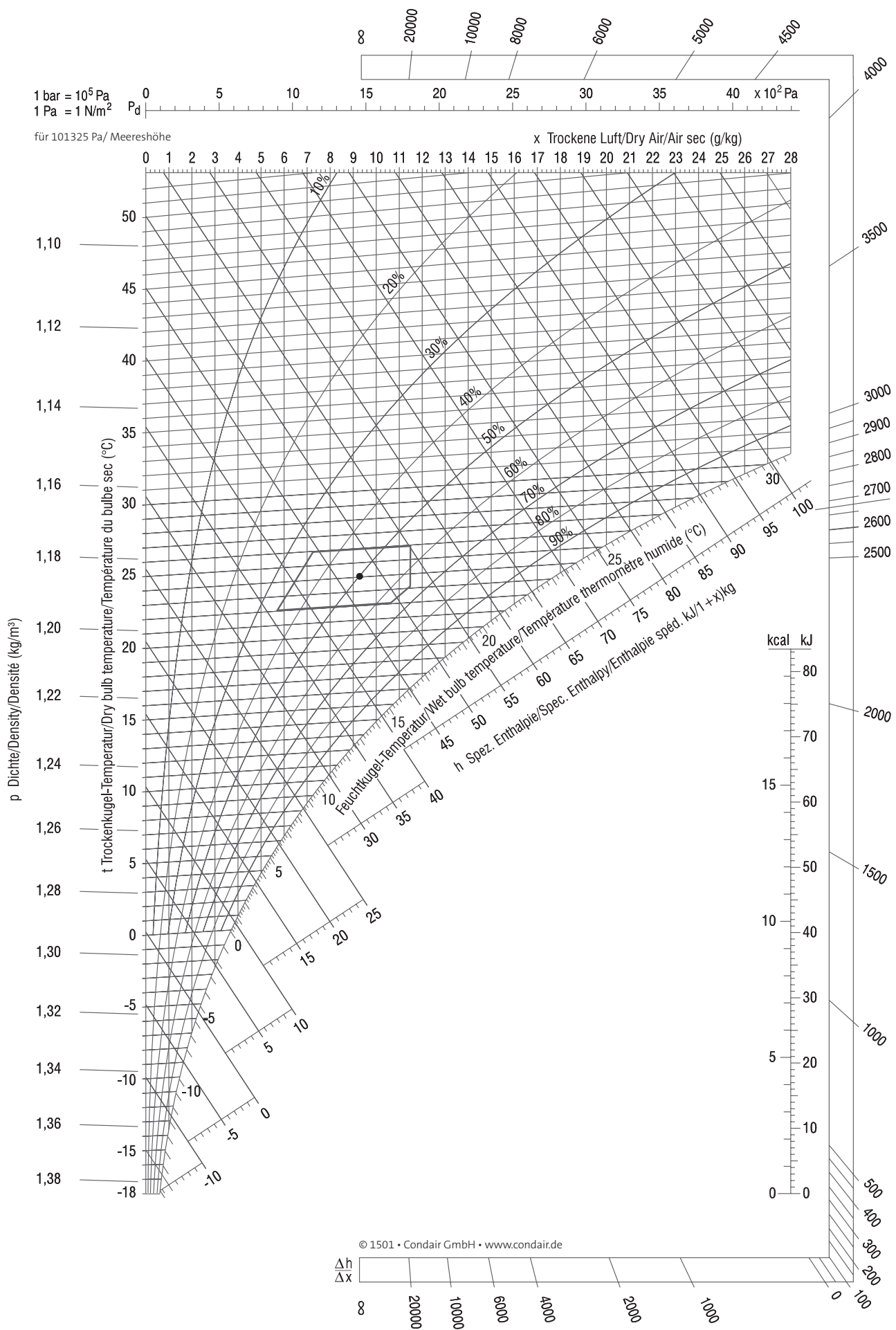

CONSULTING, SALES AND SERVICE:



CH94/0002.00

Condair Group AG
Gwattstrasse 17, 8808 Pfäffikon SZ, Switzerland
Phone +41 55 416 61 11, Fax +41 55 588 00 07
info@condair.com, www.condairgroup.com

The Condair logo, consisting of a stylized wave symbol followed by the word 'condair' in a bold, lowercase, sans-serif font.